

SOUTHERN PACIFIC 41' FLAT CAR KIT FOR 1/8 SCALE

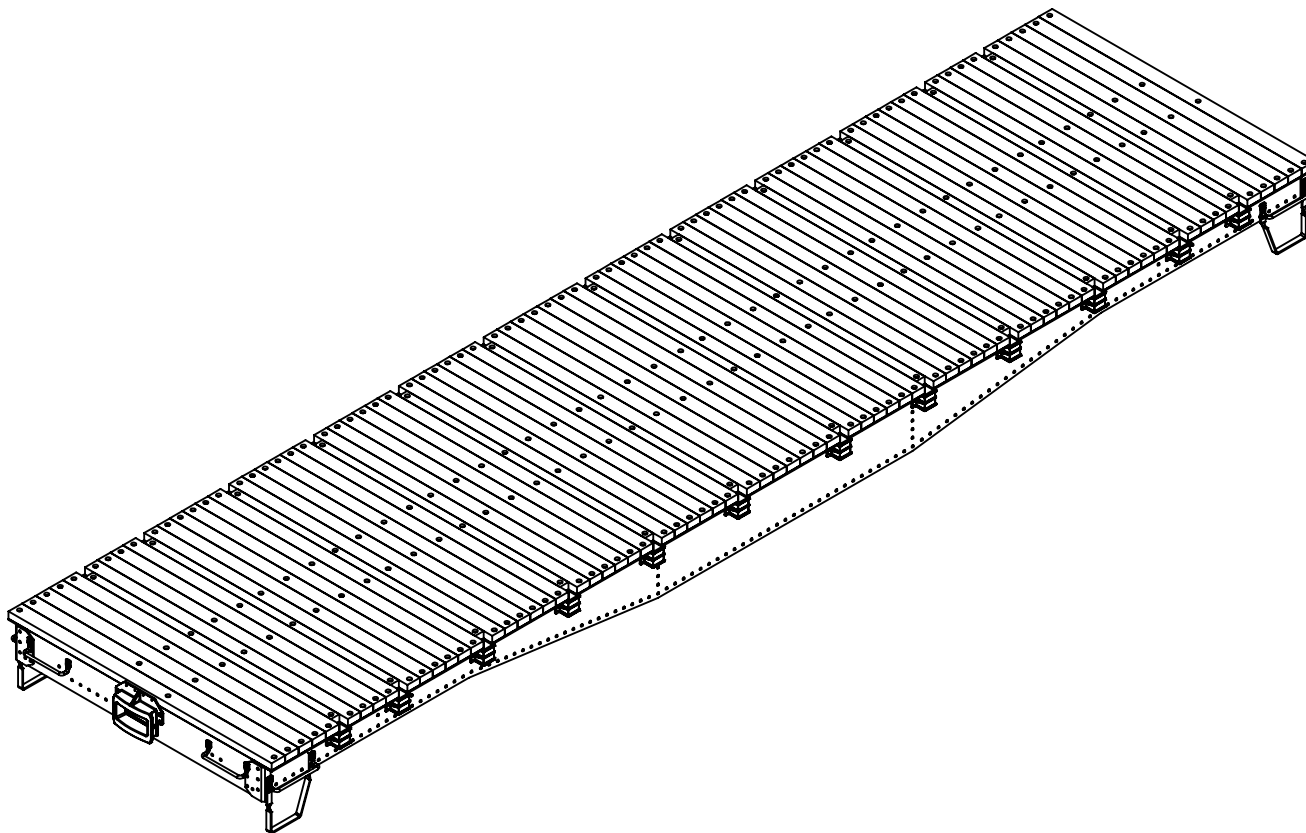

INSTRUCTION MANUAL

PACIFIC DESIGN SHOPS

REVISION: A
REVISION DATE: 3/12/21

KIT OVERVIEW

THE INFORMATION CONTAINED IN THIS INSTRUCTION MANUAL IS THE SOLE PROPERTY OF PACIFIC DESIGN SHOPS. ANY REPRODUCTION IN PART OR AS A WHOLE WITHOUT THE WRITTEN PERMISSION OF PACIFIC DESIGN SHOPS IS PROHIBITED.

Tools you may need to assemble the kit:

- Welder
- Grinder
- Clamps
- Rivet squeezer or rivet gun
- Squeezer dies, air hammer bits or bucking bar
- 1/16" Clecos (minimum 2 needed) & cleco pliers
- Cordless Drill
- 1/16" & 3/32" drill bits
- 4-40 Tap and #43 drill bit
- 2-56 Tap and #50 drill bit

Extra materials you may need (see page 3 for list of hardware):

- Trucks
- Couplers
- Truck and coupler mounting hardware
- Safety chain mounts
- Paint
- Decals

Common acronyms:

- BOM - Bill of Material
- PDS - Pacific Design Shops
- PSC - Precision Steel Car
- LSP - Live Steamer Parts
- MMC - McMaster Carr
- HRS - Hanson Rivet & Supply Co.

Helpful Tips

- Assemble kit together before welding to see how the parts go together.
- Tack weld the pieces together. It is easier to undo a tack than a bead.
- When applying the finishing welds, use skip welds instead of a continuous welding to avoid extreme warping and twisting.
- Weld from one end to the other to avoid warping.
- Use clamps to keep joints tight together when welding.

See the FAQ page for more helpful tips and answers to common questions.

We want your feedback! If you see an area to improve either on the kit or the instructions, please let us know. Send your feedback to info@pacificdesignshops.com.

PACIFIC DESIGN SHOPS IS NOT RESPONSIBLE FOR DEFECTS RESULTING FROM POOR ASSEMBLY OR CARELESS HANDLING. REPLACEMENT PARTS MAY BE AVAILABLE TO PURCHASE.

TABLE OF CONTENTS

PAGE 1	TRUCK MOUNTING OVERVIEW
PAGE 2	COUPLER MOUNTING OVERVIEW
PAGE 3	BOM OVERVIEW
PAGE 4	RIVETING SIDES
PAGE 5	RIVETING SIDES CONT.
PAGE 6	RIVETING STAKE POCKETS
PAGE 7	RIVETING ENDS
PAGE 8	WELDING FRAME
PAGE 9	RIVETING SIDES TO FRAME
PAGE 10	RIVETING CORNERS
PAGE 11	WELDING TOP PLATE
PAGE 12	WELDING BOTTOM PLATE
PAGE 13	ATTACHING DETAIL PARTS
PAGE 14	ATTACHING WOOD DECK
PAGE 15	WOOD DECK OVERVIEW
PAGE 16	FAQ'S

TRUCK MOUNTING OVERVIEW

Titan Train Mounting: Weld a 3/8" nut to back of bottom plate to bolt truck at bolster hole location. Repeat on both ends. Recommended nut: McMaster Carr P/N: 93975A300.

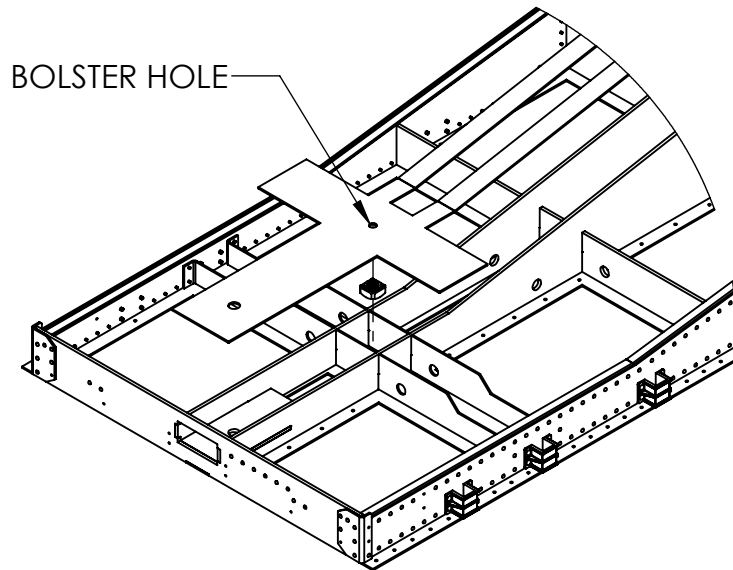

Tom Bee/LSP Mounting: Fabricate bolster plate (see below) and weld to bottom plate following the picture below. Repeat on both ends.

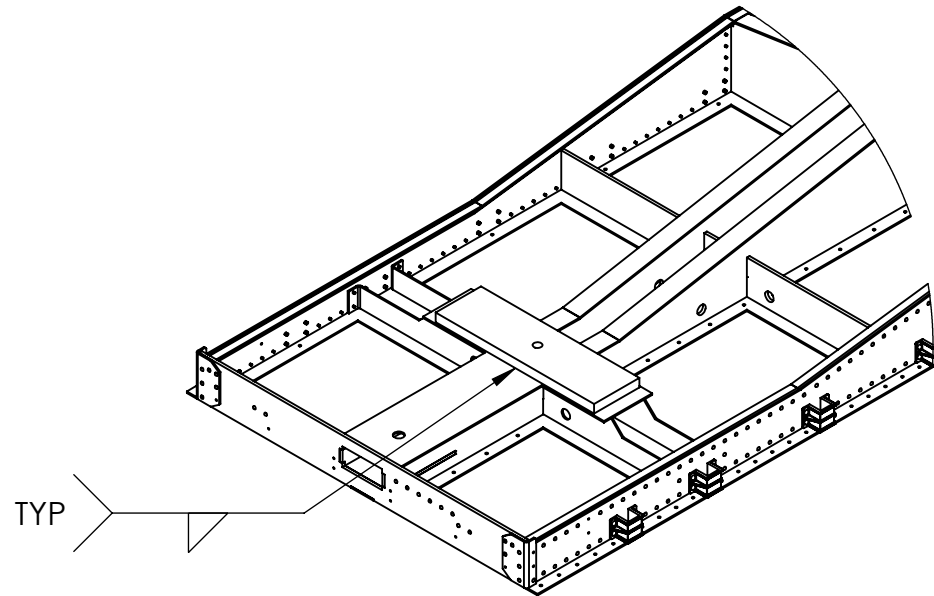

Titan Train Alternate Mounting: Use a 3/8" x 3" hex bolt and insert through bolster hole before tack welding bottom plate to frame. After final welding, use hole in top plate to plug weld top of hex bolt, making sure to keep bolt square in both directions.

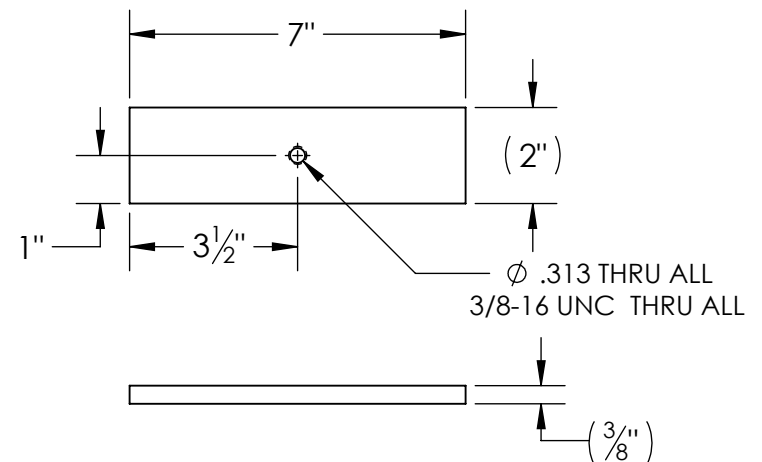

COUPLER MOUNTING OVERVIEW

For adding holes for coupler, first measure the distance from the rear face on the coupler to the coupler mounting hole location. Subtract 1" and mark that distance on bottom plate and top coupler pocket. Drill the hole per the drawing below.

Weld a 3/8" nut to the top coupler plate to allow bolt to be threaded in from below.
Recommended nut: McMaster Carr P/N: 93975A300.

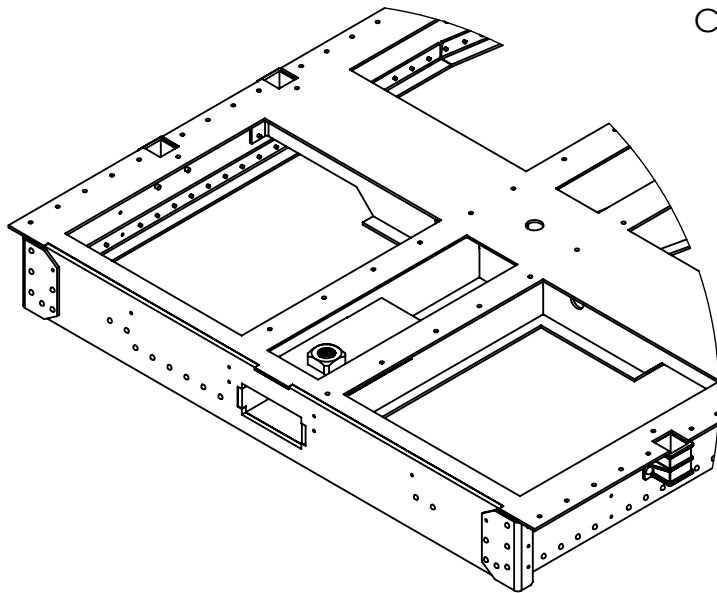

COUPLER LOCATION
DIMENSION

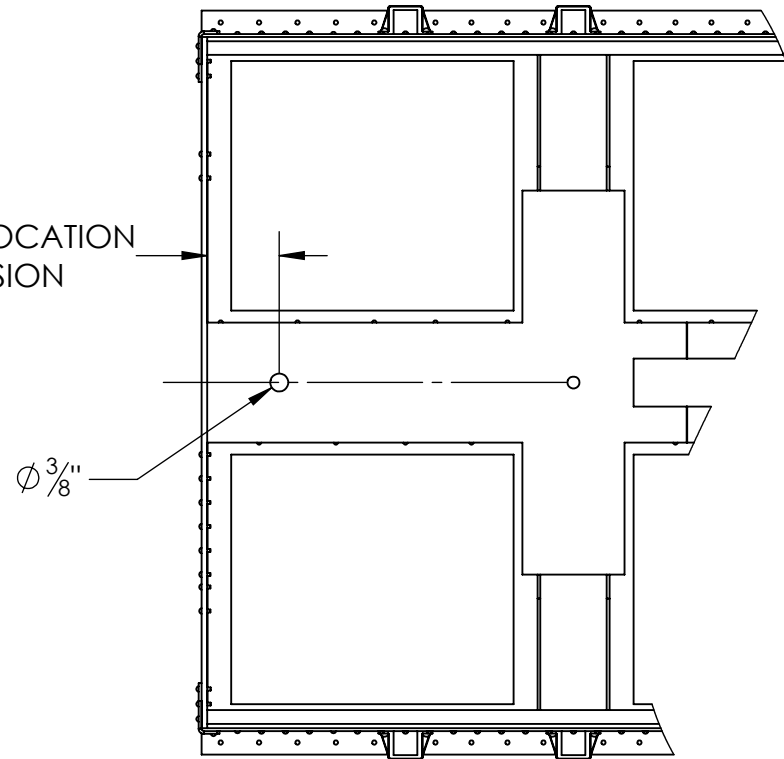

BOM OVERVIEW

- Use the BOM's below for pages 4-14
- Items below may be included in kit depending on Tier ordered.
- Rivet part numbers listed below are for copper and can be sourced from Hanson Rivet & Supply Co.

ITEM NO.	PART NUMBER	DESCRIPTION	QTY.
1	SPF75_ST11G_A2	Center Frame	2
2	SPF75_ST11G_B2	Tall Center Supports	2
3	SPF75_ST11G_C3	Short Center Supports	3
4	SPF75_ST11G_D2	End Frames	2
5	SPF75_ST11G_E2	Top Coupler Plate	2
6	SPF75_ST16G_A2	Side Frames	2
7	SPF75_ST16G_B4	Bolster Supports	4
8	SPF75_ST16G_C2	Corner A	2
9	SPF75_ST16G_D2	Corner B	2
10	SPF75_ST16G_E1	Top Plate	1
11	SPF75_ST16G_F1	Bottom Plate	1
12	SPF75_ST16G_G2	Side Angles	2
13	SPF75_ST16G_H4	Stirrup Steps	4

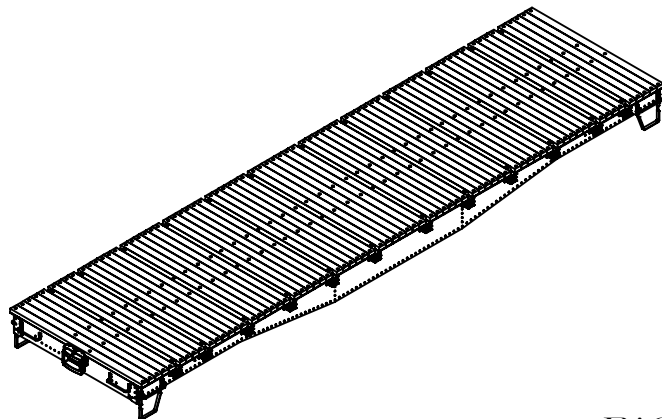

Recommended Copper Rivets

ITEM NO.	PART NUMBER	DESCRIPTION	QTY.
14	HRS_35C0202	1/16" x 1/8"L Rivet	178
15	HRS_35C0203	1/16" x 3/16"L Rivet	278
16	HRS_35C0204	1/16" x 1/4"L Rivet	24
17	HRS_35C0303	3/32" x 3/16"L Rivet	96

Recommended Detail Parts

ITEM NO.	PART NUMBER	DESCRIPTION	QTY.
18	PSC_F-011	Flat Car Stake Pocket	24
19	PSC_G-A-2250	Single Drop Grabiron 2¼"	4
20	PSC_G-A-2500	Single Drop Grabiron 2½"	4
21	N/A	Deck Boards	1
22	N/A	Coupler Pocket	2

Recommended Hardware

ITEM NO.	PART NUMBER	DESCRIPTION	QTY.
23	MMC_92949A076	2-56 x 3/16" BHCS, 18-8 SS	8
24	MMC_92949A106	4-40 x 1/4" BHCS, 18-8 SS	24
25	MMC_92196A108	4-40 x 3/8" SHCS, 18-8 SS	255

STEP 1: RIVETING SIDES

Assemble side angles along bottom of side frames using 1/16" x 3/16" long rivets and shown in **Detail A**. Start in the middle and work towards either end. Use clecos to hold the position of the angle while riveting. Note locations in **Detail B** to skip. Repeat for both sides.

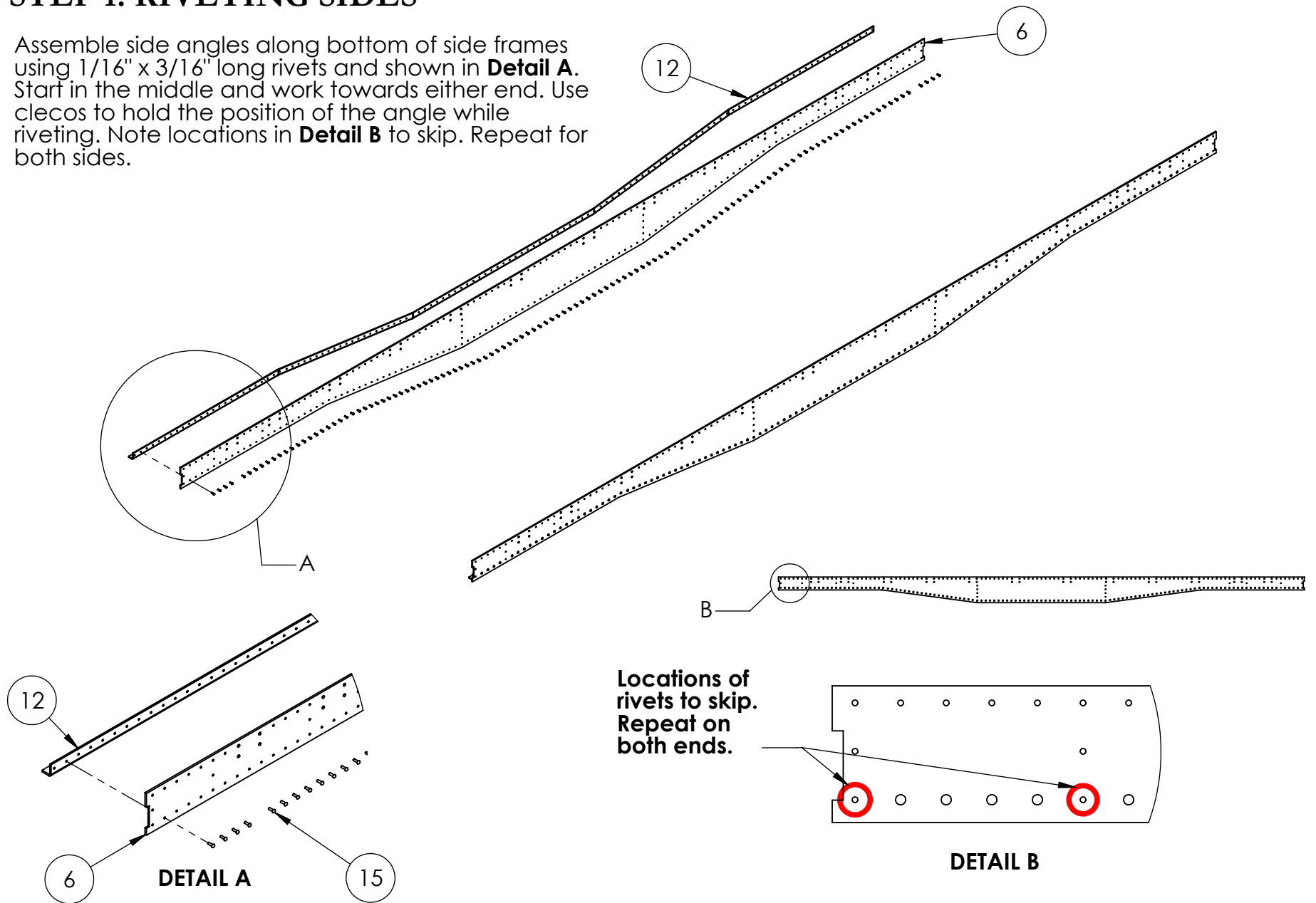

STEP 2: RIVETING SIDES CONT.

Assemble 1/16" x 1/8" long rivets to sides in remaining 1/16" holes in side frames as shown in **Detail C**. Note locations to skip in **Detail D**. Repeat for both sides.

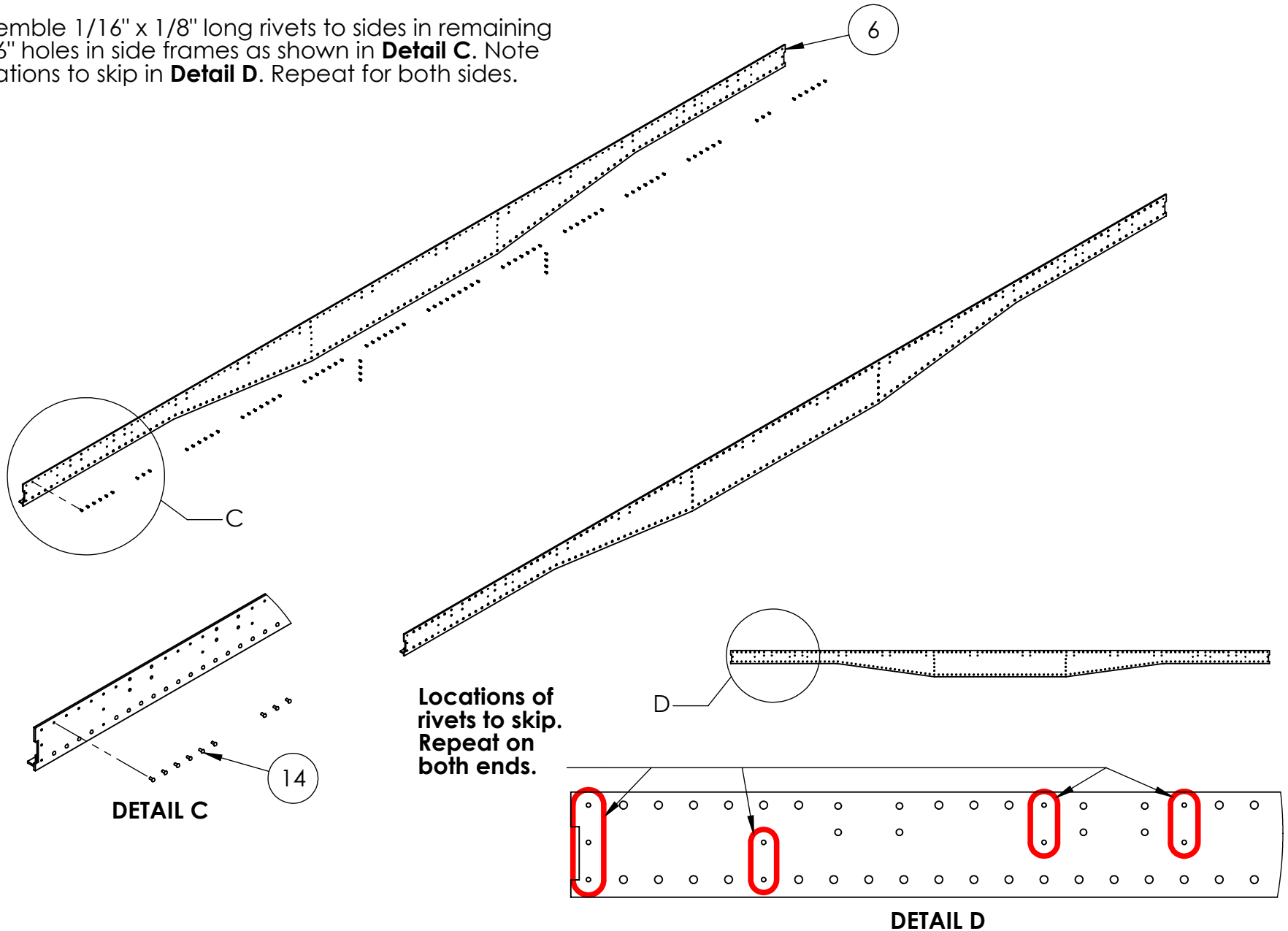

Locations of rivets to skip. Repeat on both ends.

DETAIL D

STEP 3: RIVETING STAKE POCKETS

Assemble stake pockets to sides using $3/32"$ x $3/16"$ long rivets as shown in **Detail E** & **Detail F**. Repeat for both sides.

*****NOTE***** Width of stake pocket can be adjusted by squeezing/stretching to align holes. Use minimal force to make adjustments. Drilling holes larger than $3/32"$ in side frames or stake pockets is not required.

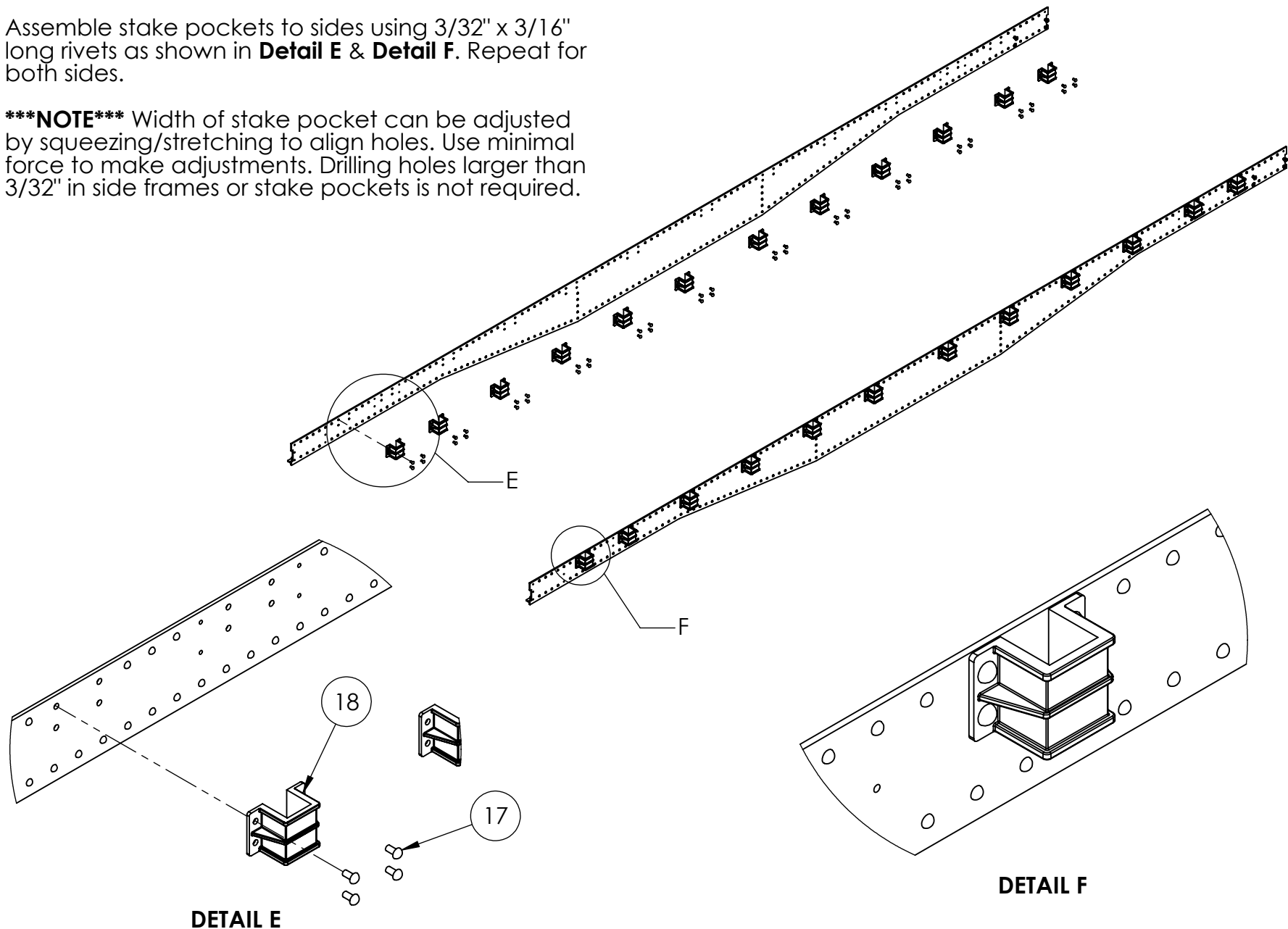

DETAIL E

DETAIL F

STEP 4: RIVETING ENDS

Assemble 1/16" x 1/4" long rivets to ends frames as shown in **Detail G**. Note locations to skip in picture below. Repeat for both ends.

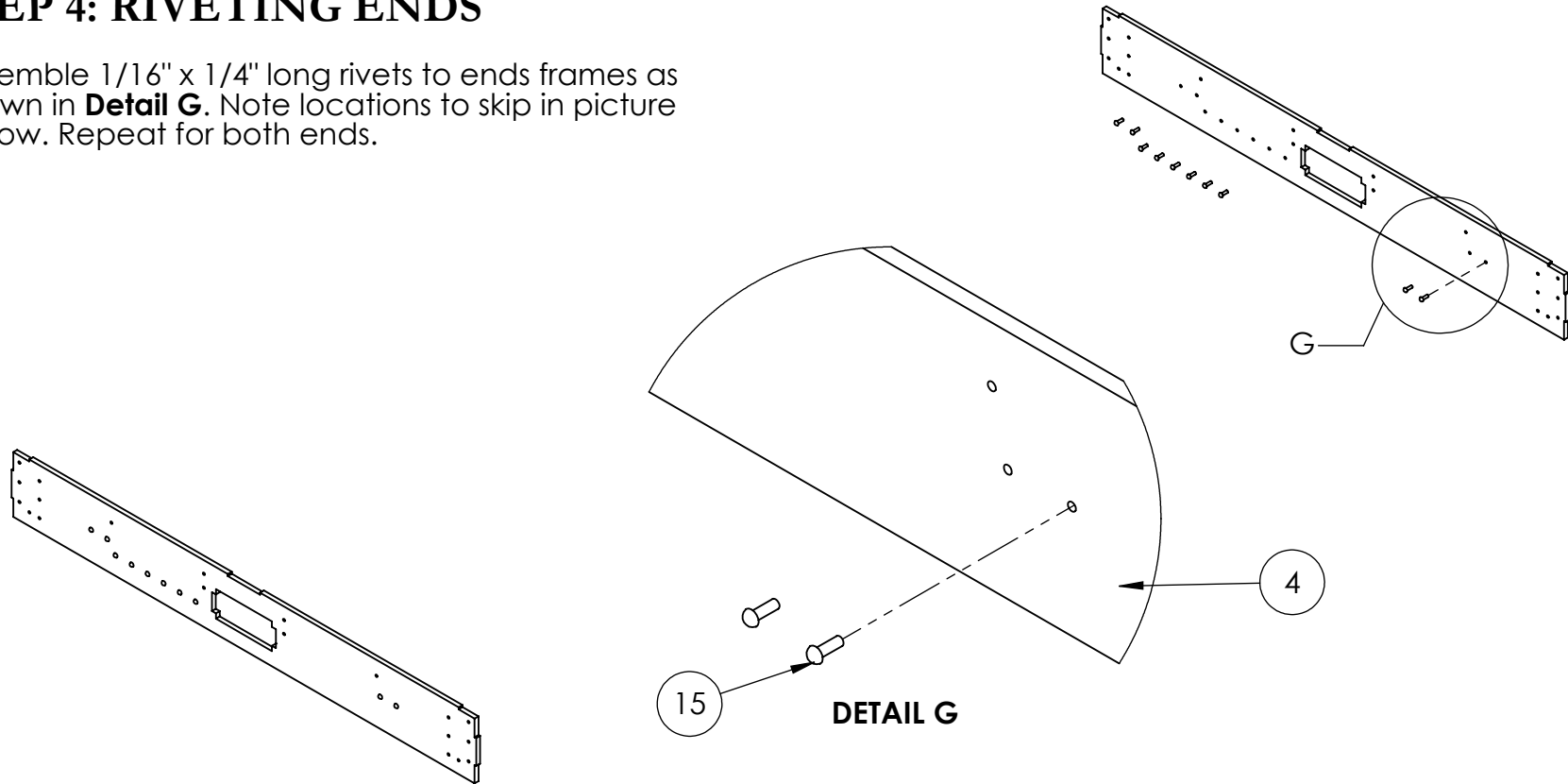

Locations of rivets to skip.

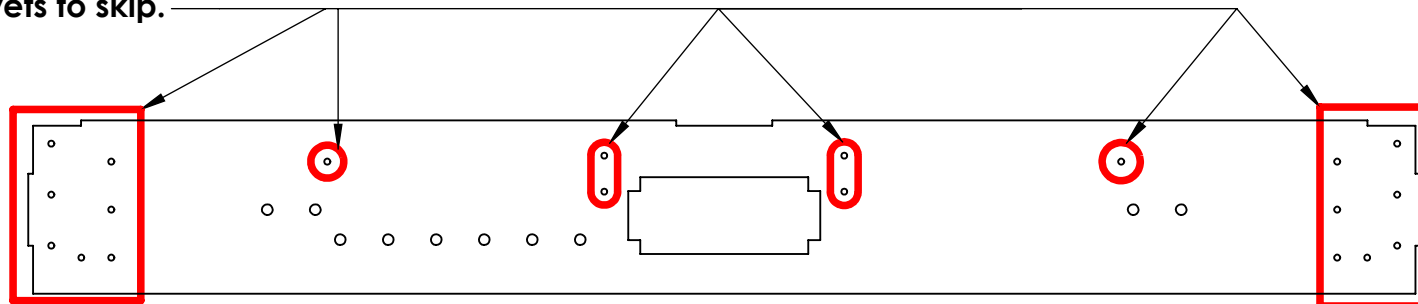

STEP 5: WELDING FRAME

*****TACK WELD ONLY*****

Assemble frame as shown below. Make sure provisions have been completed for mounting couplers. Use top decking to align and straighten center frame. Apply tack welds keeping care to avoid holes for rivets and screws.

DO NOT WELD TOP PLATE TO FRAME AT THIS STEP.

MAKE SURE PROVISIONS
HAVE BEEN MADE FOR
MOUNTING COUPLERS

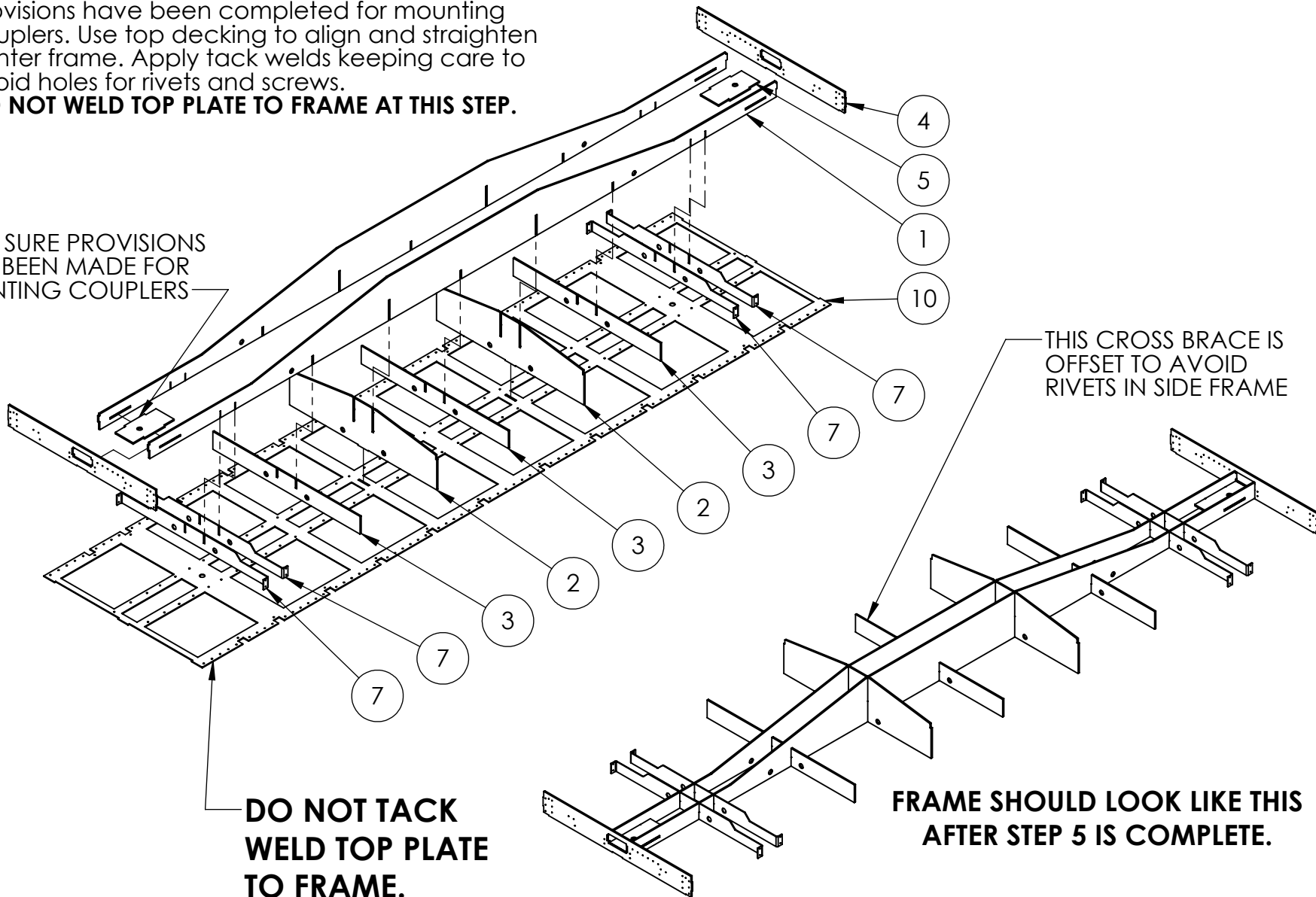

**DO NOT TACK
WELD TOP PLATE
TO FRAME.**

**FRAME SHOULD LOOK LIKE THIS
AFTER STEP 5 IS COMPLETE.**

STEP 6: RIVETING SIDES TO FRAME

Assemble side assemblies to frame using 1/16" x 3/16" long rivets as shown in **Detail H**. Repeat for both sides.

DO NOT WELD SIDES TO FRAME AT THIS STEP.

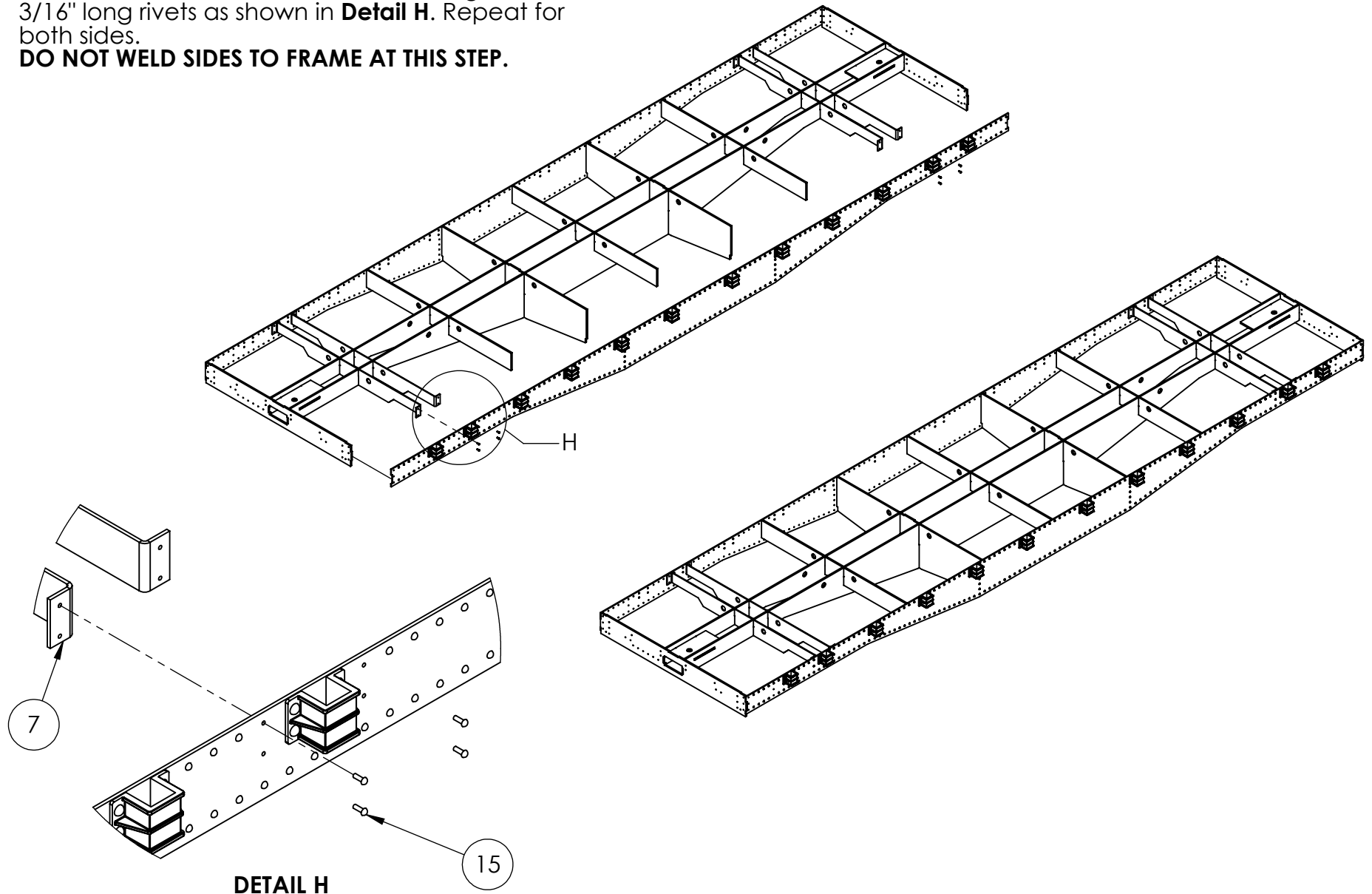

STEP 7: RIVETING CORNERS

Assemble corners angles to sides and frame using $1/16"$ x $1/4"$ long & $1/16"$ x $3/16"$ long rivets as shown in **Detail J**. Grind corner for angle to fit. Note locations of rivets to skip in **Detail K**. Repeat on both sides and ends.

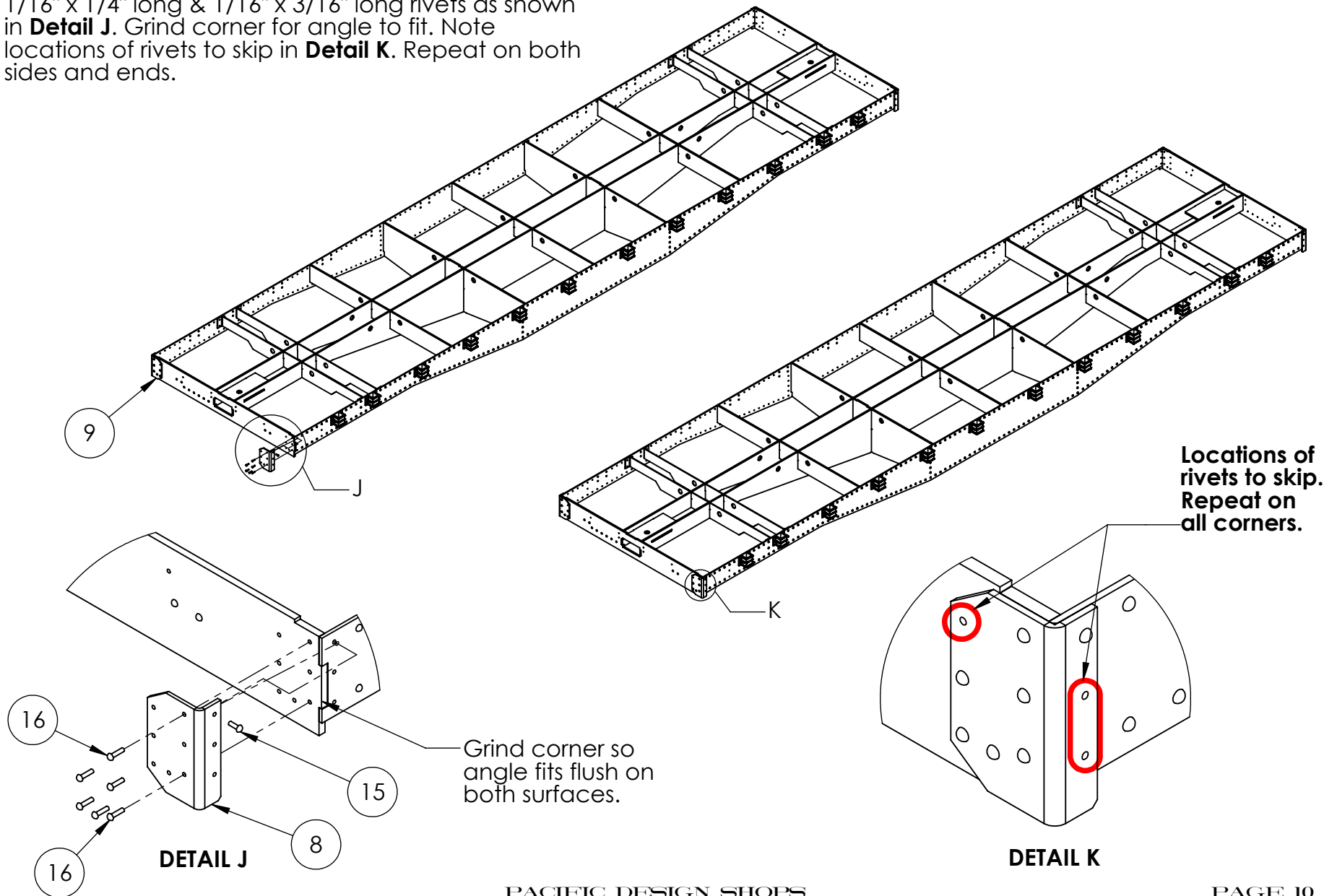

STEP 8: WELDING TOP PLATE

Tack weld top plate to frame and side assembly. Make sure locating tabs are fully inserted and no gaps occur between frame and top plate.

*****TACK WELD ONLY*****

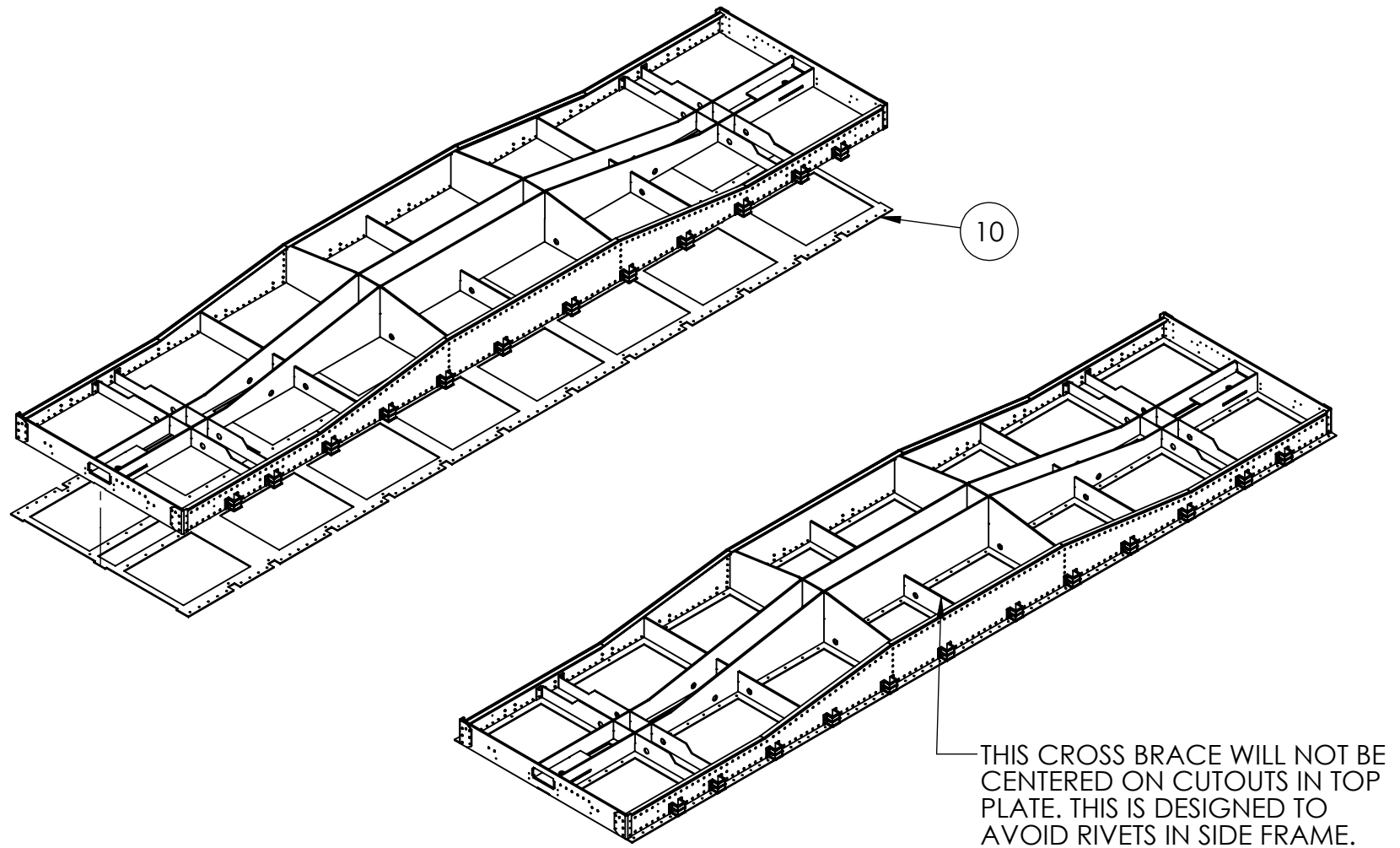

STEP 9: WELDING BOTTOM PLATE

Center bottom plate and tack weld to frame. **MAKE SURE PROVISIONS FOR TRUCKS AND COUPLERS HAVE BEEN COMPLETED PRIOR TO ASSEMBLY.** Bend down stringers and tack weld to frame.

Once bottom plate is tack welded, go back and apply finish welds on car.

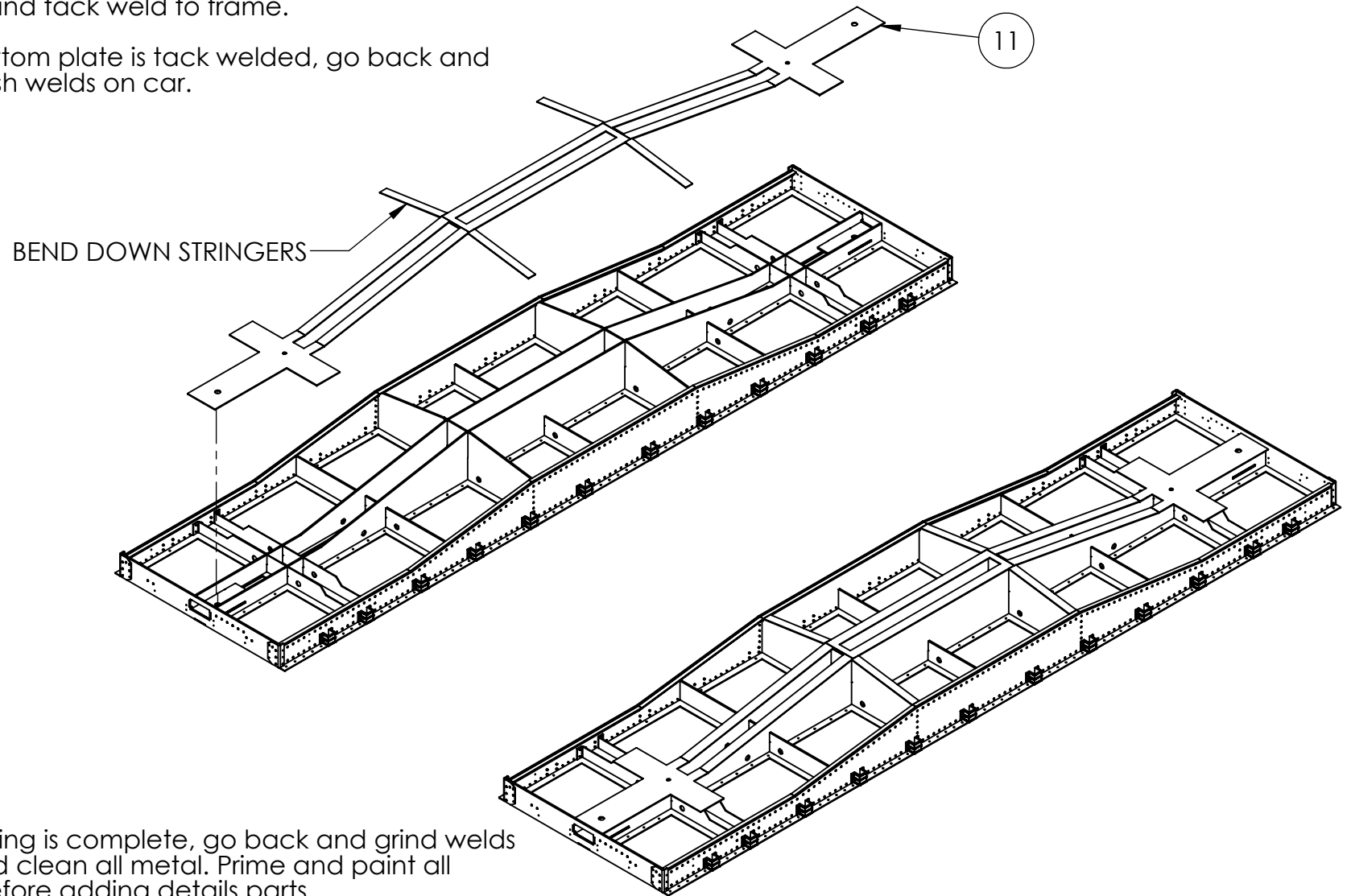

Once welding is complete, go back and grind welds smooth and clean all metal. Prime and paint all surfaces before adding details parts.

STEP 10: ATTACHING DETAIL PARTS

Assemble detail parts to ends of car as shown in **Detail L & Detail M**.

Drill all holes for coupler pocket with a #50 drill bit and tap 2-56 for hardware.

Drill all holes for grabirons & stirrup steps with a #43 drill bit and tap 4-40 for hardware.

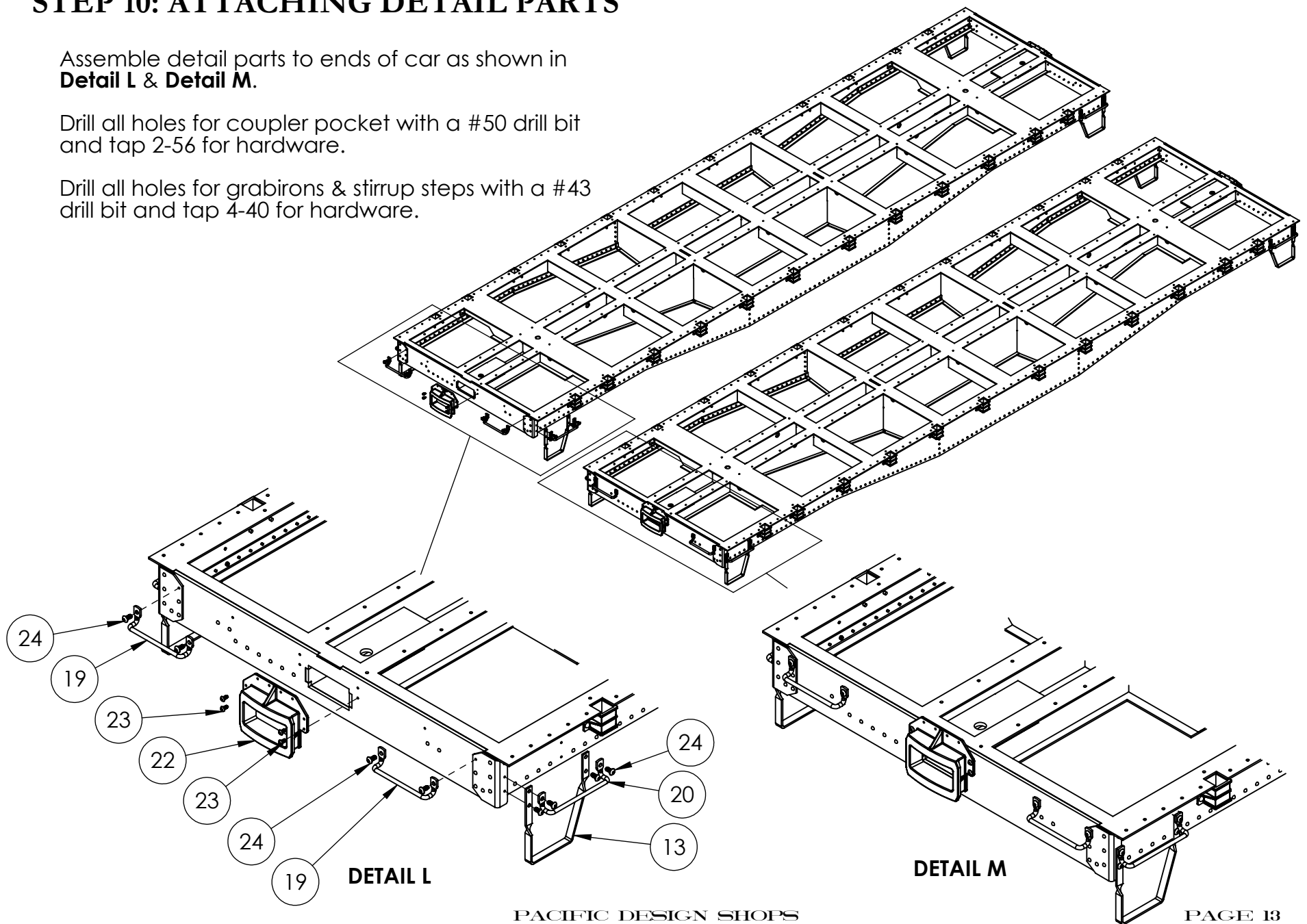

STEP 11: ATTACHING WOOD DECK

Drill and tap the top plate for 4-40. Attach wood deck with 4-40 screws as shown in **Detail N**. See page 15 for location and sizes of wood deck boards.

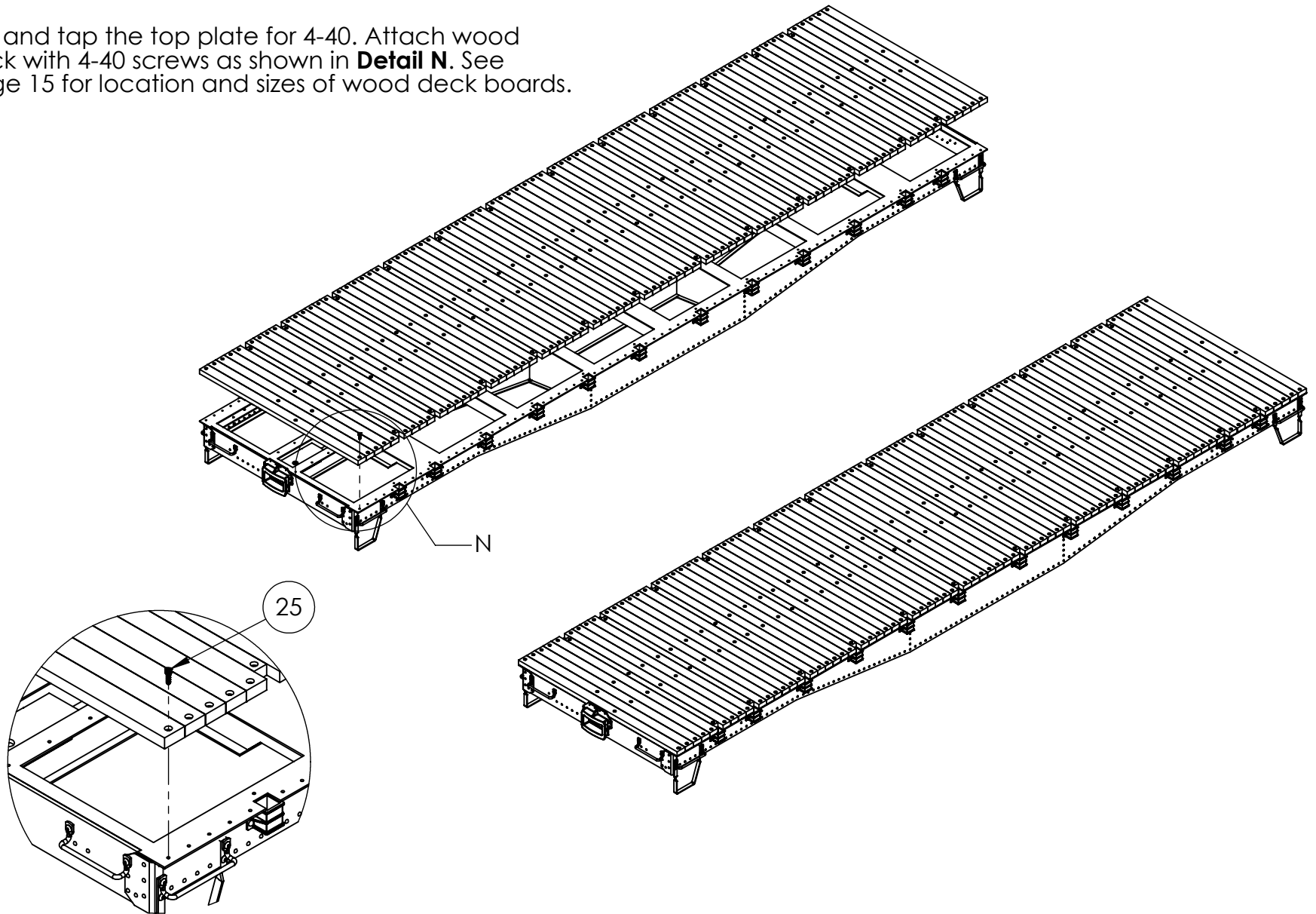

DETAIL N

WOOD DECK OVERVIEW

- All deck boards are 3/8" thick.
- If staining deck boards, plane width 0.010" under nominal to allow for swelling.
- Drill deck for appropriate fasteners. Recommendations are listed below for a #4 screw.
- Flip ever other board end to end to attach to deck (note hole locations in center of car). Repeat pattern on other end.

BOARDS				HOLE POSITIONS		
Type	QTY	Width	Length	Hole 1	Hole 2	Hole 3
A	10	0.8"	15.5"	0.25"	6.5"	15.25"
B	12	0.5"	14.5"	0.25"	6"	14.25"
C	56	0.75"	15.5"	0.25"	6.5"	15.25"
D	7	0.786"	15.5"	0.25"	6.5"	15.25"

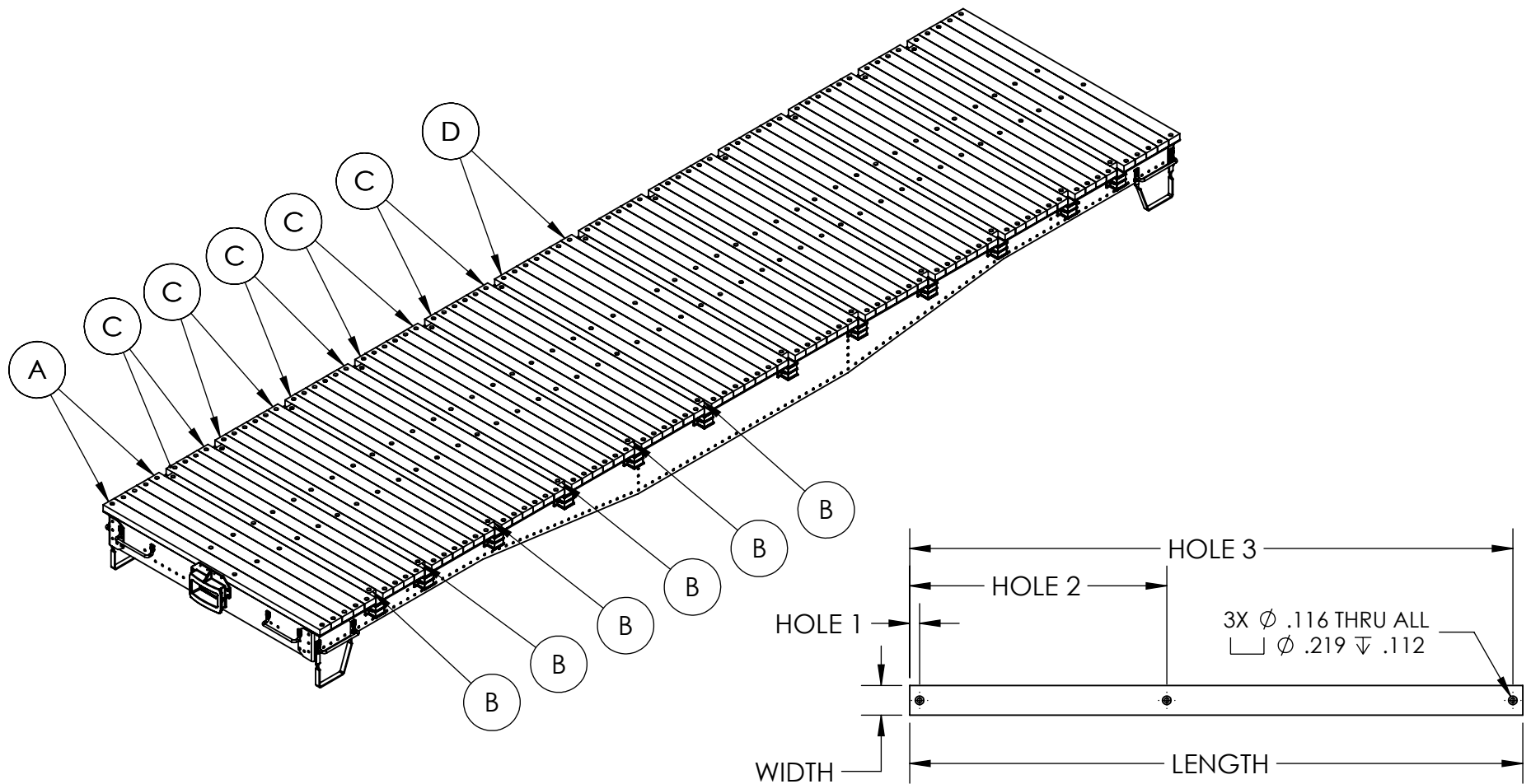

FREQUENTLY ASKED QUESTIONS

Q: My frame isn't fitting together and there are gaps, what is going on?

A: Care was taken in the design to incorporate tab and slot construction to avoid having to use jigs or special clamps to hold items in the correct positions for welding but that also increases the locations for interferences to occur. Wiping down all the parts prior to welding is a good first step to remove grit from mating surfaces that may have accumulated from storage or the manufacturing process. Because of the laser cutting process used to cut out the parts, there may be some burrs on the corners. Use a file or grinder to remove them. Making sure to fit all the parts together before welding will help you locate where a problem is before items are welded together. During welding, weld BB's may get stuck to faces and should be grinded off as the steps are followed.

Q: I bought a completed kit that is E-coated. What is E-coating and how do I paint it?

A: E-coating is an immersion wet paint finishing process that uses electrical current to attract the paint product to a metal surface. While the process is similar to powder coating, it differs in that the part is held in a fluid bath that ensures all surfaces are coated helping to protect surfaces that may be difficult to access when painting. Before the part is E-coated, it is dipped in a chemical bath to remove oil and grit from the surface. After the part is E-coated, it is ready to accept almost all paints with minimal prep work required. E-coating does make the part come out black, but if you want your project to be black, you need to protect the coating with a top coat. E-coating is not UV stable and will break down in sunlight if not covered.