

RIDE ASTRIDE CAR KITS FOR 1/8 SCALE 5' AND 6' VERSIONS

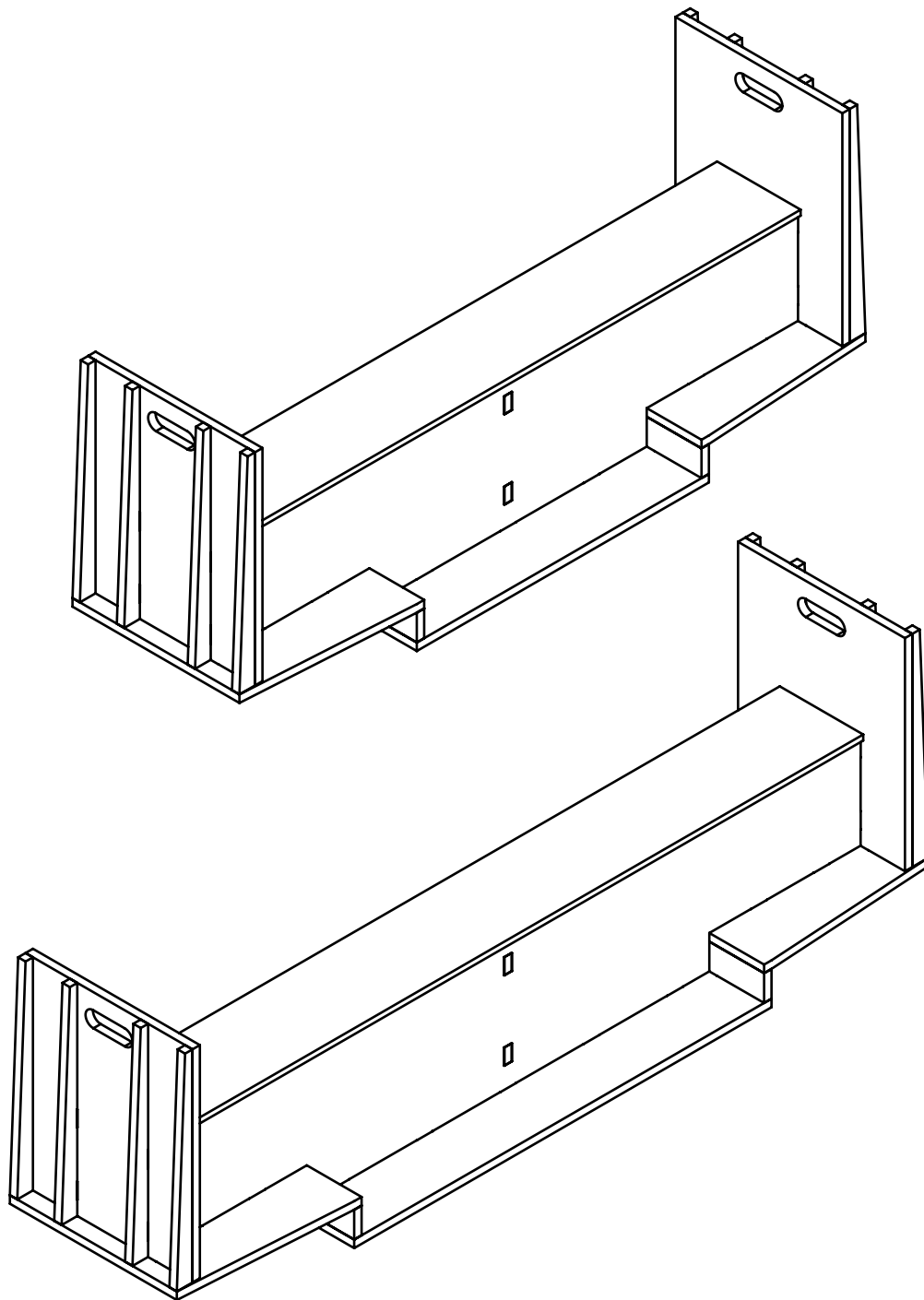

THE INFORMATION CONTAINED IN THIS INSTRUCTION MANUAL IS THE SOLE PROPERTY OF PACIFIC DESIGN SHOPS.
ANY REPRODUCTION IN PART OR AS A WHOLE WITHOUT THE WRITTEN PERMISSION OF PACIFIC DESIGN SHOPS IS PROHIBITED.

What's included:

Part A: 5' Version

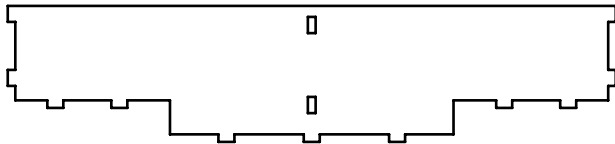

Quantity 2

Part A: 6' Version

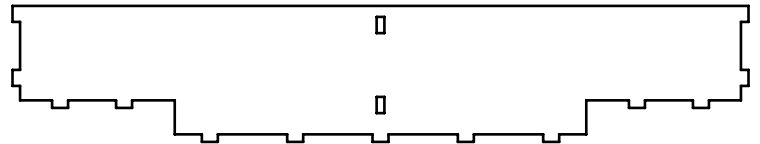

Quantity 2

Part B

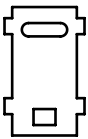

Quantity 1

Part C: 5' Version

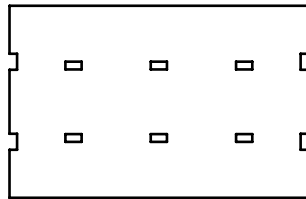

Quantity 1

Part C: 6' Version

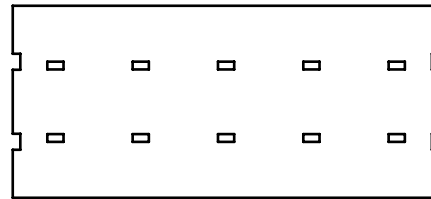

Quantity 1

Part D

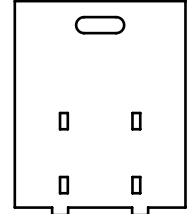

Quantity 2

Part E

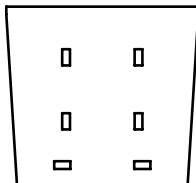

Quantity 2

Part G



Quantity 8

Part F



Quantity 2

Part H: 5' Version

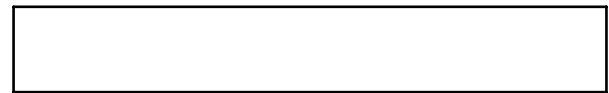

Quantity 1

Part H: 6' Version



Quantity 1

Tools needed:

- Drill
- 3/32" Drill Bit
- Screw Driver



Materials Needed:

- #6 x 1-1/2" Wood Screws (or drywall screws)
- Wood Glue (Titebond III recommended)

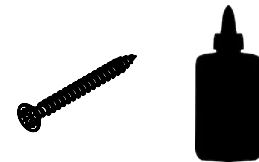

Other Recommended Materials:

- Wood Putty
- Trucks
- 1"x2"x0.120" wall Steel Rectangular Tubing
- Mounting Hardware for Trucks/Couplers
- Hinges for Seat (optional)
- Sand Paper
- Couplers
- Paint

The following instructions and views reflect the 6' version. The 5' version follows the same assembly process. Any differences between the two sizes are noted in the instructions.

Because plywood varies from sheet to sheet, it is best to assemble the car together to check for fit and to note any problem areas before gluing; some sanding may be required. Kit should go together with minimal effort, do not force pieces together.

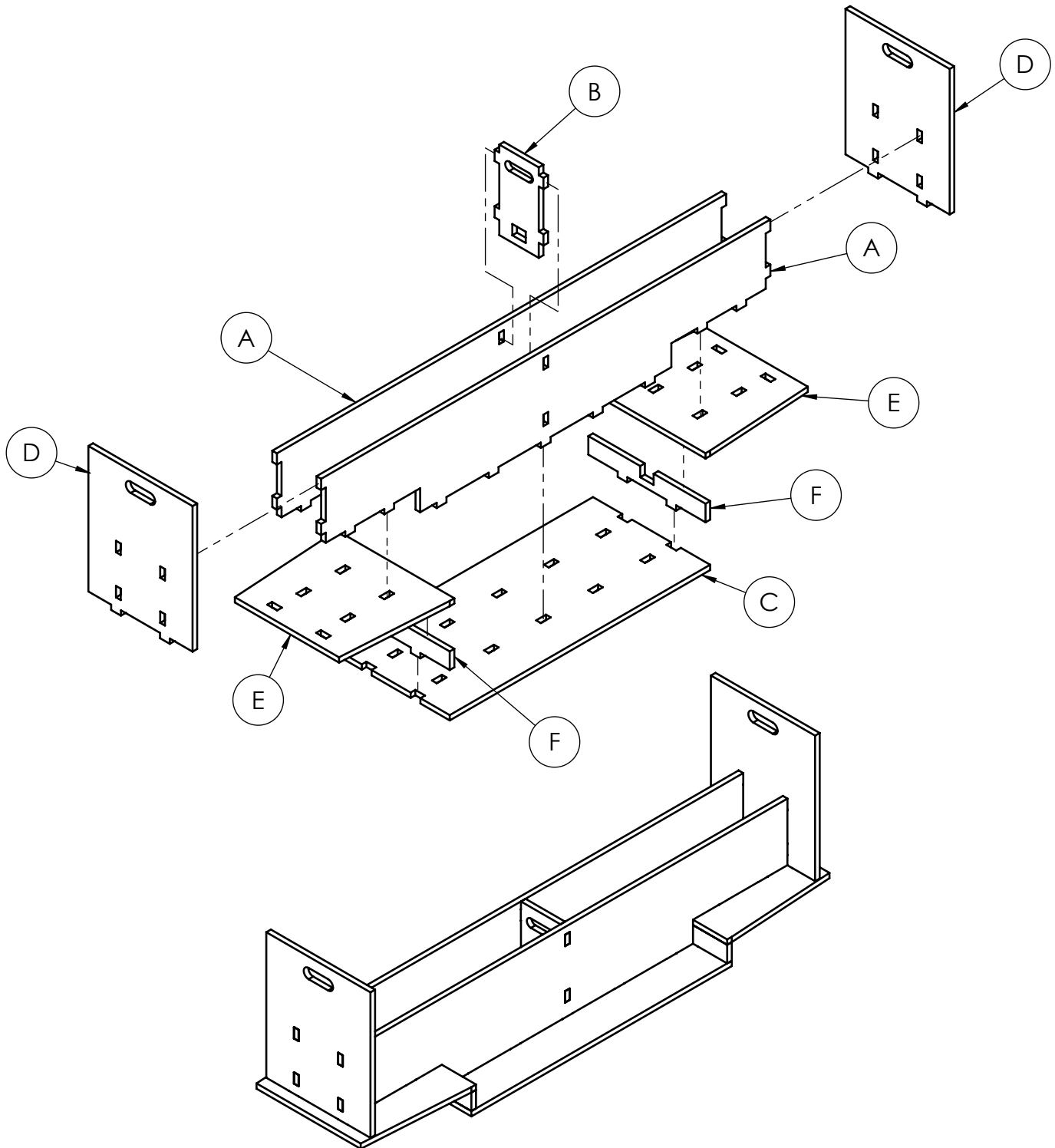

Assembly Recommendations

Before final gluing and assembly, sand the hand holds as it is easier to do this before the car is assembled together (especially on part B). Another option is to use a 1/4" round-over bit in a router to smooth over the hand holds.

In the instructions to follow, the steps will show locations to screw the parts together. While the location is not called out, it is recommended to place the screws between the square cutouts in the pieces. An example is shown below. Pre-drill all holes with a 3/32" drill bit to prevent splitting.

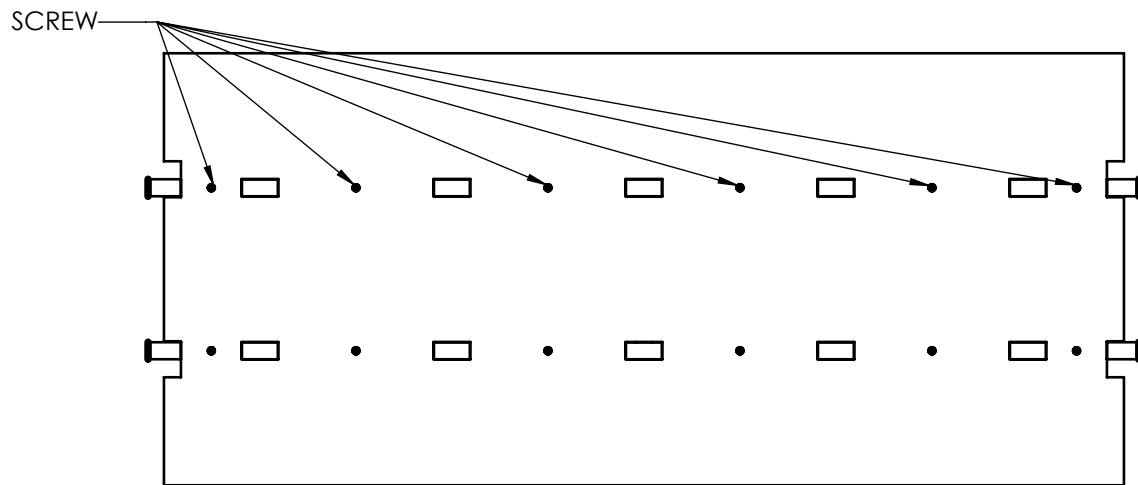

Do not use more screws than each step recommends. The screws are just there to hold the parts together as the glue dries.

The car can also be assembled without screws but will require a large collection of different sized clamps to complete the glue up.

Apply enough glue on each joint to provide some squeeze out. Use a damp rag for cleaning up excess glue before drying.

Finally if parts A are bowed, clamp a 2"x4" to the edge while gluing up to prevent the car from being glued together in a curved form. The pockets in the parts will also help to prevent this.

If you have additional questions on the assembly of the kit or if you have concerns, please contact us at info@pacificdesignshops.com.

Enjoy!

STEP 1:

Glue part B to parts A. Note the orientation of the hand hold on part B when mating pieces together. Place a clamp across the top to hold the parts together.

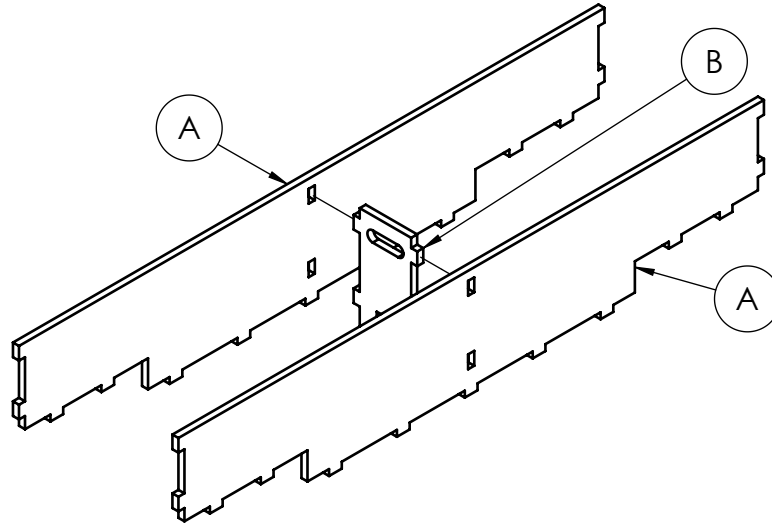

STEP 2:

Glue and screw part C to assembly from step 1 using 12 screws.

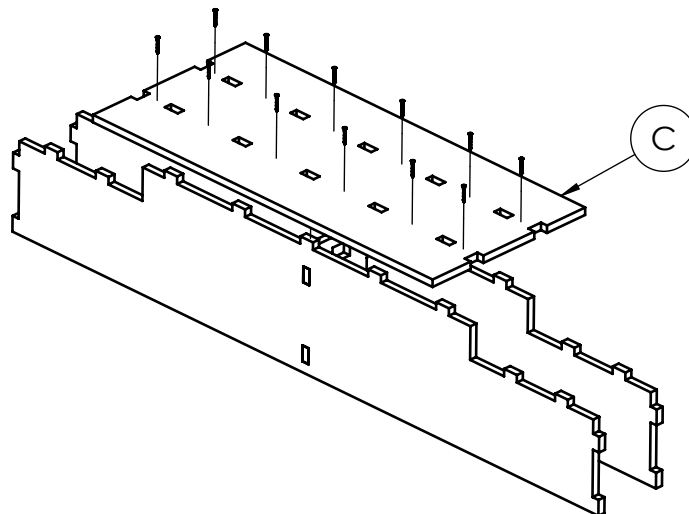

STEP 3:

Glue and screw parts D to assembly from step 2 using two screws on each end.

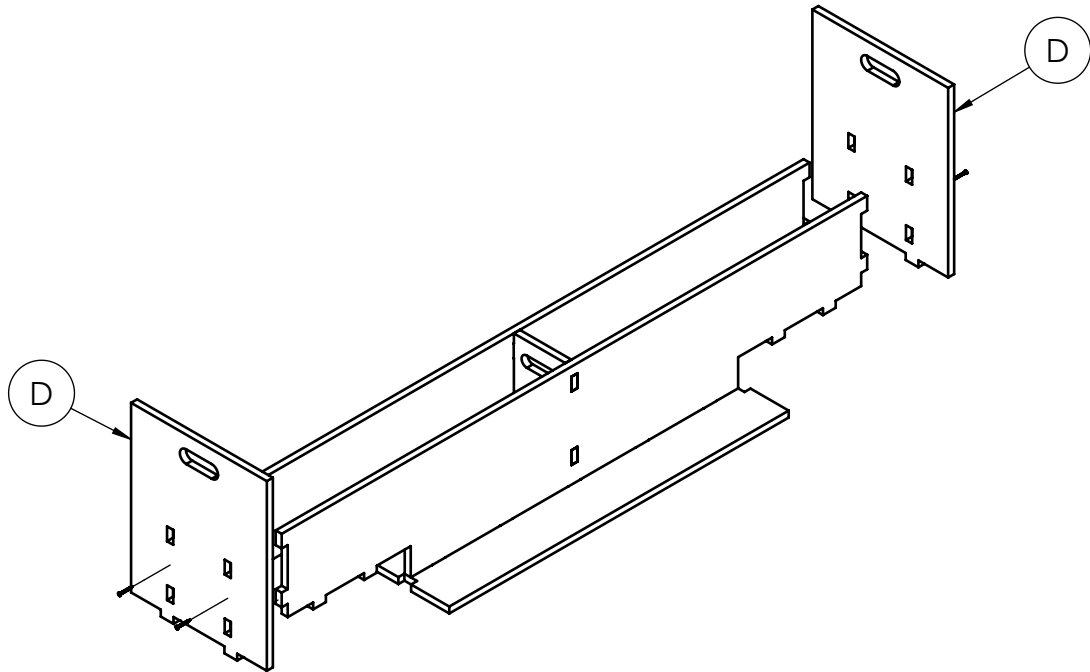

STEP 4:

Glue and screw parts E to assembly from step 3 using 9 screws on each end.

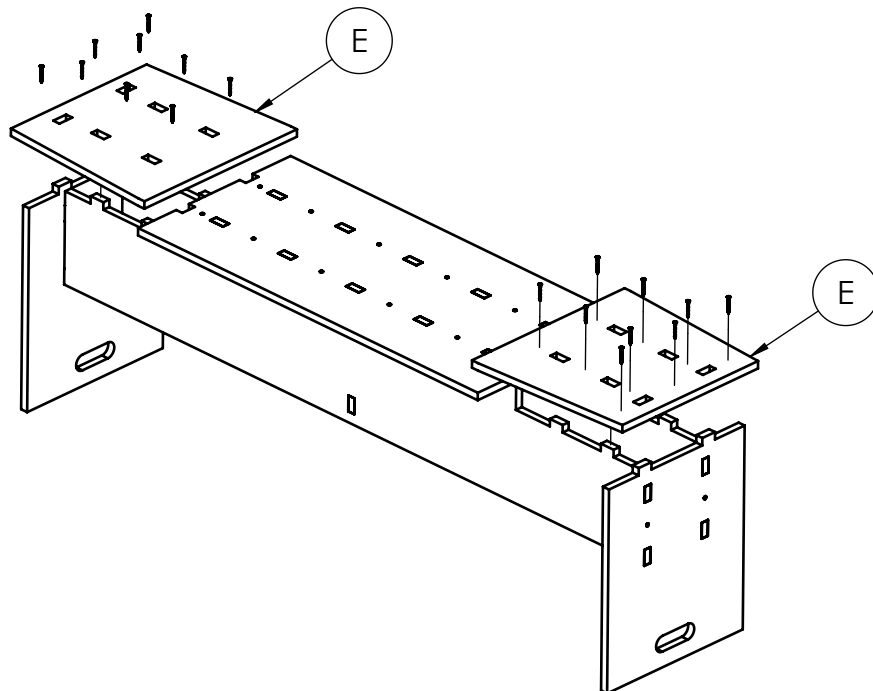

STEP 5:

Glue parts F to assembly from step 4. Place clamps to eliminate gaps between parts C, E, & F.

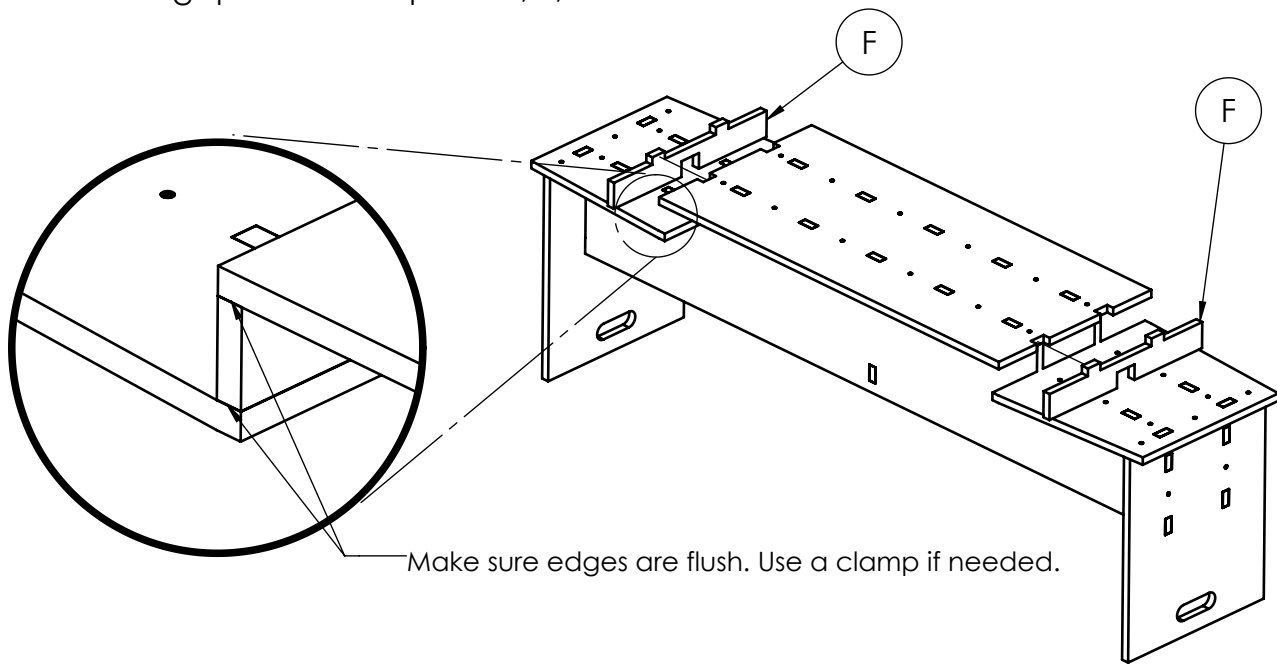

STEP 6:

Glue parts G to assembly from step 5. Note locations using dimensions below. Make sure to place the 90° corner of part G into the edge created by parts D & E to avoid gaps.

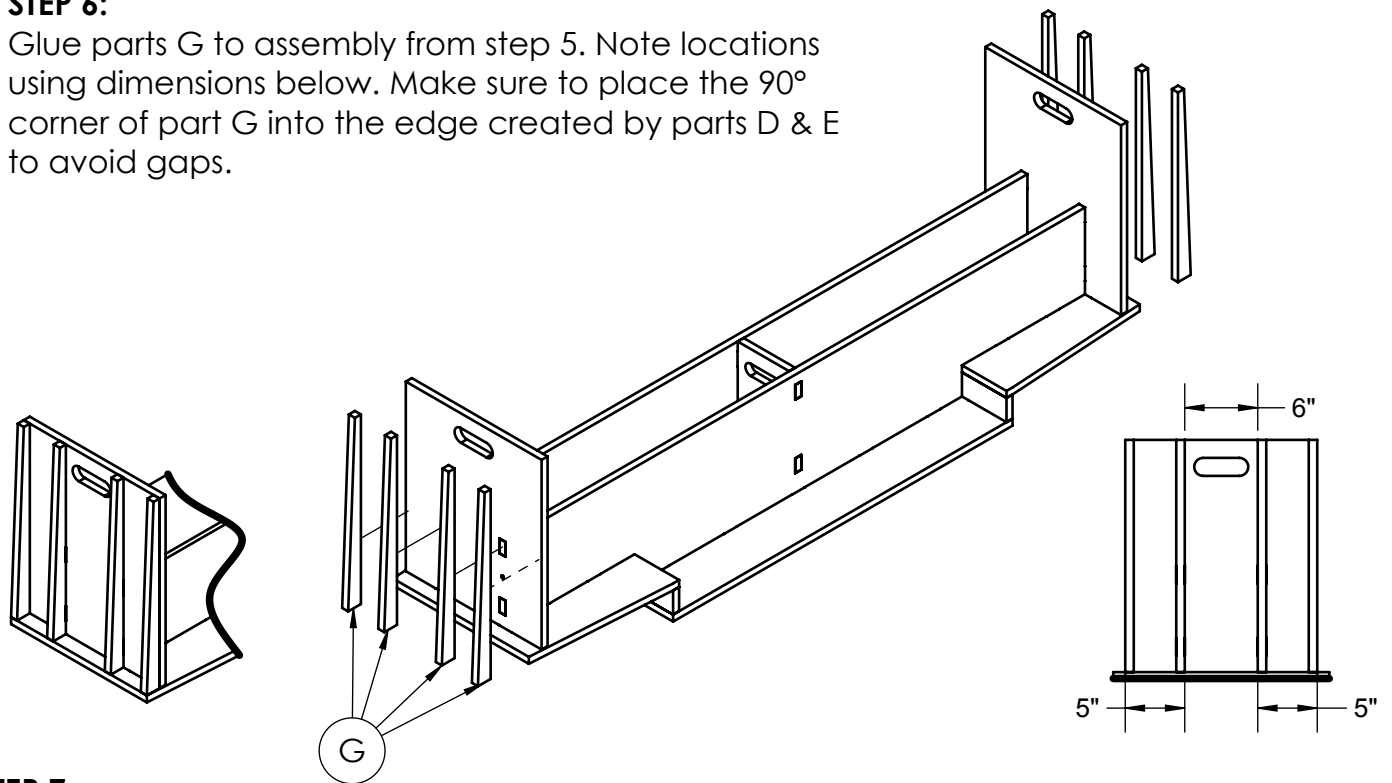

STEP 7:

The kit is now complete. Let the glue dry and fill and holes that are needed. If mounting a 1"x2" steel tubing, see the examples on the following pages for mounting couplers and trucks. Attach the seat (Part H) with hinges or glue strips of wood under the seat to prevent it from sliding around. Finally sand and paint the car to protect the wood from the elements before final assembly.

Truck/Coupler Mounting

STEP 8:

Using a piece of 1"x2"x0.120" steel tubing, cut to length and drill per drawing below. Slide tubing through cutouts in car and drill through for mounting hardware. (See notes)

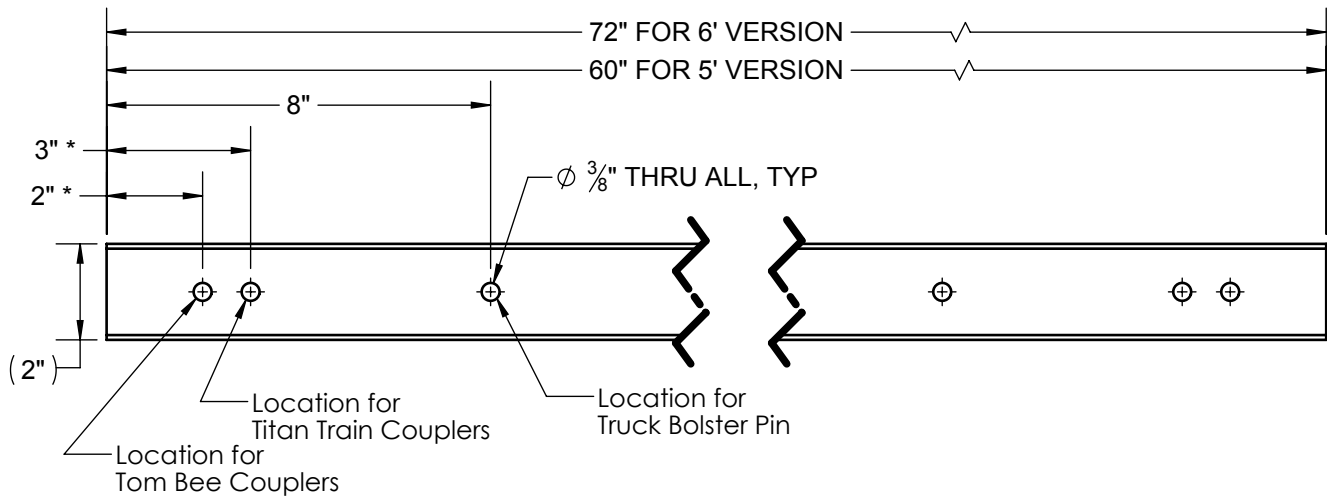

NOTES:

- The dimensions listed for the couple position should be used as guidelines. It is best to use the couplers to determine final position.
- **Optional:** If the position of the coupler is less than $2\frac{3}{4}$ " from the end of the tubing, mark hole locations on car then remove tubing and counterbore to provide relief for bolt head (Figure 1). There is $\frac{1}{2}$ " of vertical clearance between the cutouts and tubing (Figure 2), this allows the frame to be lowered in order to clear the bolt head for the coupler. To assemble, slide the frame past the coupler hole, install the coupler with bolt and nut, repeat on other end, center the frame, push frame against bottom of car to seat coupler bolts in counterbores. If using optional coupler method, drill another $\frac{3}{8}$ " hole through the frame 4" from the ends to mount the frame rigidly to the car.
- **For Tom Bee Trucks:** Place a $\frac{1}{2}$ " spacer between the tubing and wood body to prevent the wheels rubbing on the bottom of the wood body when loaded. The sides of the shipping crate can be used as the spacer.

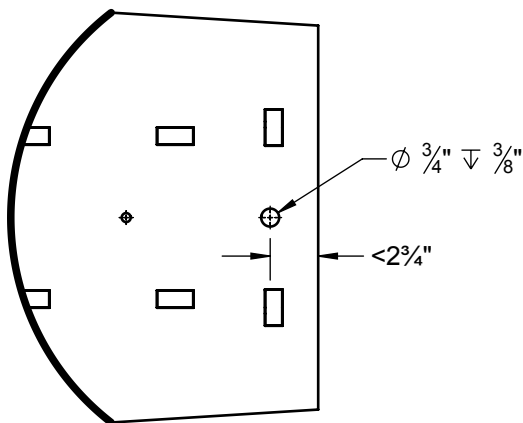

Figure 1

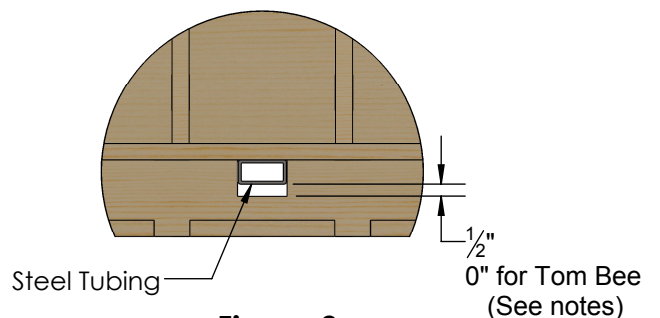

Figure 2

Truck Bolster Mounting

Titan Trains

STEP 9a:

Cut (4) pieces of $\frac{3}{4}$ " plywood to the dimension listed below and glue to the car per Figure 3.

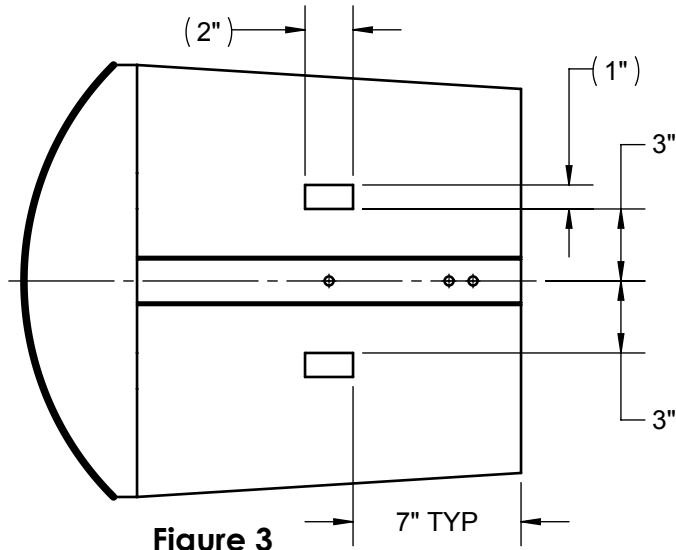
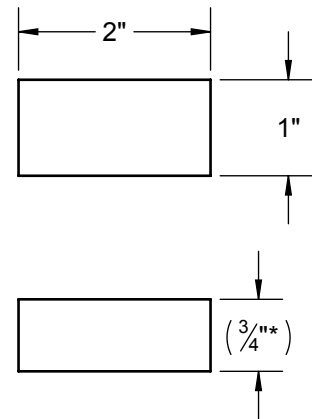

Figure 3



STEP 9a cont:

Cut and drill (4) bolster pads from $\frac{1}{4}$ " steel. Screw onto wood supports. (Figure 4) Make sure heads of screws sit slightly below surface of pad.

Drill & Countersink per screw size

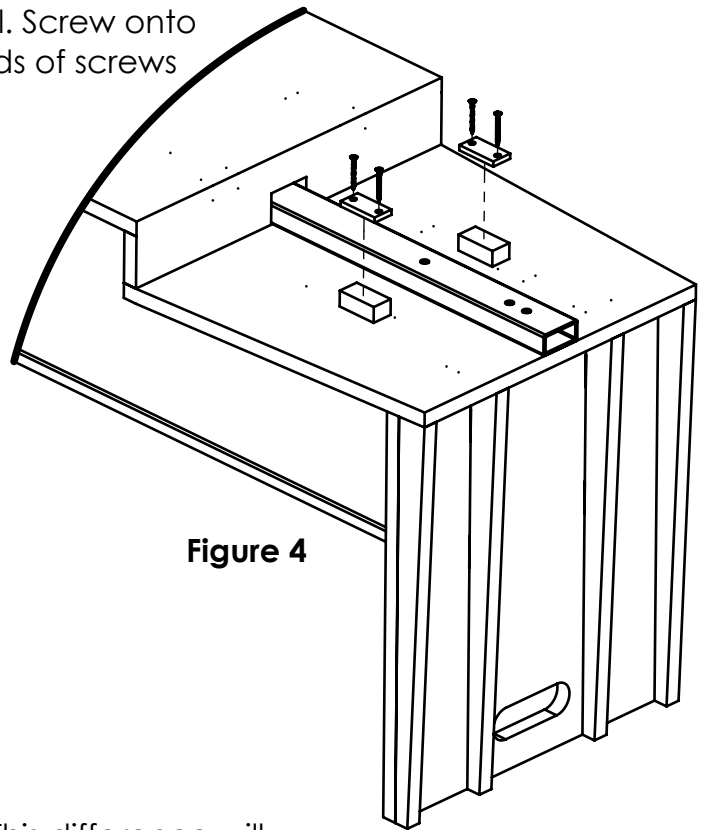
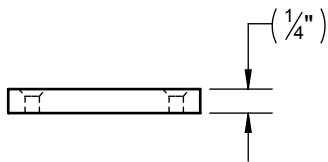
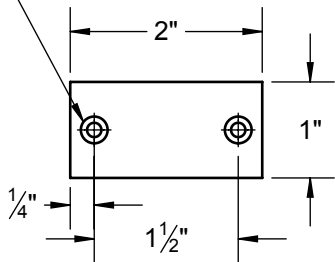

Figure 4

NOTES:

- $\frac{3}{4}$ " plywood is typically $\frac{23}{32}$ " thick. This difference will usually create enough vertical distance for the truck to rock side to side to take up track abnormalities. Adjust this distance by adding spacers to get the desired rock.

Truck Bolster Mounting

Tom Bee/Live Steamer Parts

STEP 9b:

Cut (4) pieces of 1" wood (1½" for Tom Bee) to the dimension listed and glue to the car per Figure 5. Make sure tops of wood supports are flush with steel tubing.

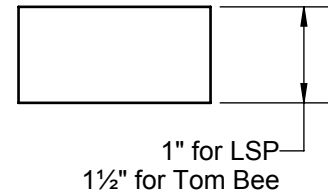
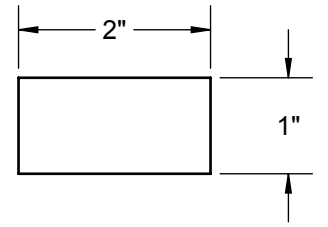
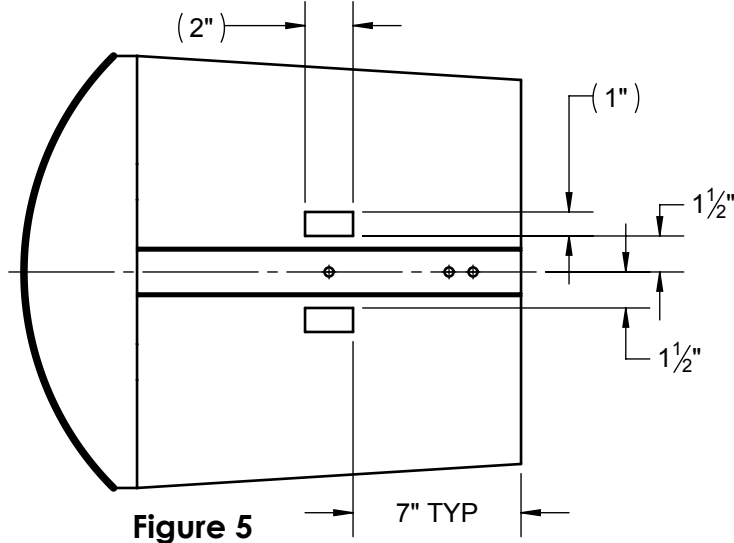

Figure 5

STEP 9b cont:

Cut and drill (2) bolster pads from 3/8" steel. Screw onto wood supports. (Figure 6)

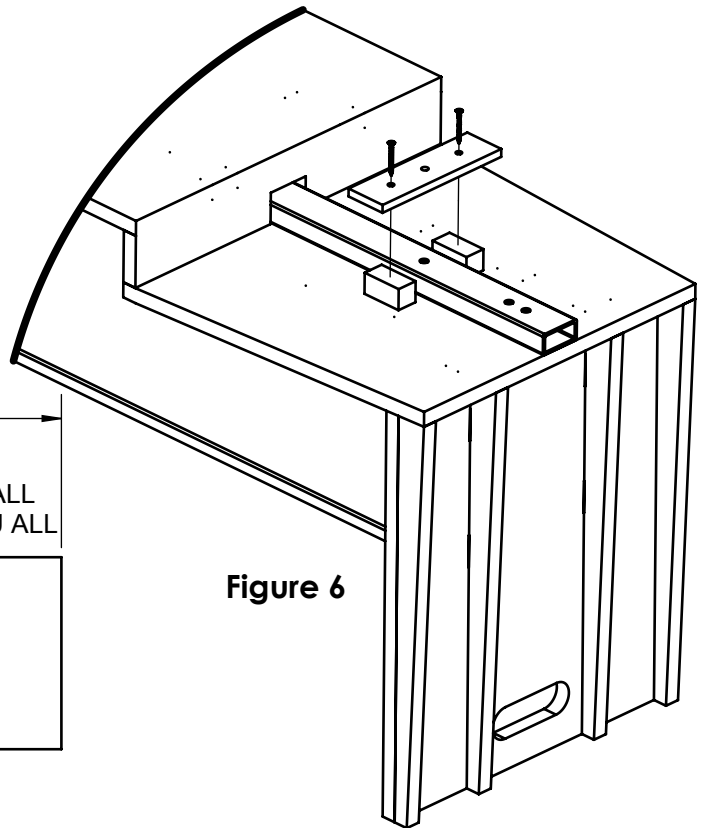

Figure 6

